



View of the new, high-quality amplifier described in this article.

High-Quality Audio Amplifier With Automatic Bias Control

Exceptionally low distortion and uniform response over a wide frequency range are features of this audio amplifier. Power triodes operating with automatic bias control are used in the output stage.

The simplest definition of a high-quality amplifier is "An amplifier which reproduces sound indistinguishable from the original." Broken down into its technical elements, it requires that:

1. All audible frequencies shall be amplified uniformly.

2. No new audio components shall be introduced. Harmonic and intermodulation distortion should be at such an extremely low value that they are not detectable in themselves and, more important, do not contribute to "listening fatigue."

3. The gain shall be uniform at all signal levels. Amplitude distortion shall be inaudible.

4. Transient waveforms shall be transmitted without distortion.

If one or more of the above elements is lacking, the sound is not natural and cannot be called high quality. For instance, a flat audio characteristic extending from 20 to 20,000 cycles, if it is not free from distortion, is actually disagreeable and far less acceptable than a much narrower audio range, from 100 to 4000 cycles, with the same amount of distortion. When distortion, or noise such as static, hiss or needle scratch, is present in any part of the system the most pleasing sound is to be obtained with some attenuation of the high frequencies.

To produce a high-quality sound sys-

J. R. EDINGER

Brook Electronics, Inc.

tem, distortion of all kinds must first be reduced to the vanishing point, and then the audio-frequency range must be widened to the full limits of audibility. Then, and only then, will the reproduced sound be comparable to the original.

Listening fatigue is a very important, but intangible, factor in high-quality reproduction. There is frequently a

strong desire to stop listening, even though a good reproducing system is being used. This is evidently a result of having excessive intermodulation and high-order harmonic distortion, which is not readily detectable during listening. It is, therefore, very necessary in a high-quality amplifier to keep distortion to as low a value as possible, even though it may not be apparent.

Low-mu triode tubes were chosen for the Brook high-quality amplifier, be-

Fig. 1. Fundamental circuit for automatic bias control. See text.

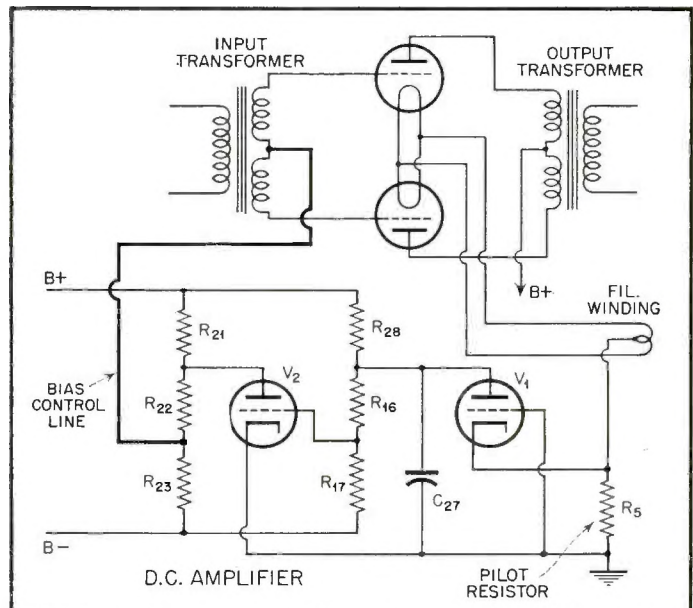

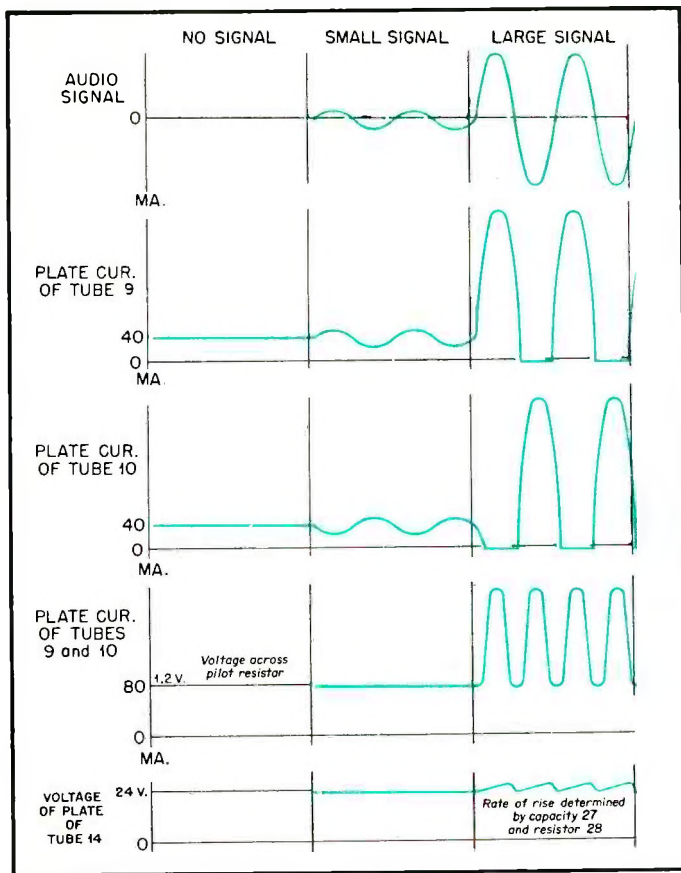

Fig. 2. Manner in which the plate currents of the output tubes vary for small and large input signal voltages.

cause triodes inherently are almost completely free of high-order distortion. Pentodes and beam power tubes have slight kinks in their characteristics curves which produce exceedingly small amounts of very high order harmonic and intermodulation distortion. These amounts, while hardly measurable, are yet believed to be responsible for the listening fatigue.

A number of tests have shown that when a good speaker system is used, extending the frequency range from 8,000 to 14,000 cycles produces a very desirable increase in listening pleasure when triodes are used.

The same tests were made with the best amplifiers available using beam power tubes and pentodes employing feedback. The increased range was definitely irritating. There was the desire to stop listening. The only evidence found to produce this listening fatigue was intermodulation and high-order harmonic distortion.

The same tests were again repeated with a triode amplifier, but the triode amplifier's bias was purposely set to give a small step or kink in the tube's characteristic curve. This amplifier then also produced what we call listening fatigue.

Automatic Bias Control

The problem was to build an amplifier where the bias would always be of correct value. The Brook amplifier accomplishes this by using automatic bias control.

The automatic-bias-control (a.b.c.) circuit used in this amplifier is a recent development. It was developed and patented by Lincoln Walsh for use in audio amplifiers and other electronic devices shortly before the war.

The purpose of a.b.c. is to operate the amplifier at the desired condition for maximum distortion and highest efficiency. The a.b.c. circuit reduces the harmonic distortion and the intermodulation distortion values to a new low.

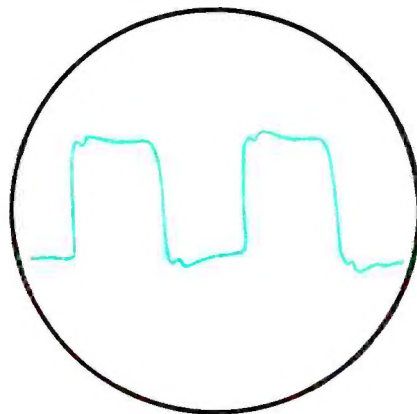

Fig. 3. Oscillogram of 5000-cycle square wave after passing through this amplifier. This indicates good transient response.

This amplifier with a.b.c. operates as a pure class A system up to 5 watts output; then there is a smooth transition to class AB₂ operation up to 30 watts output with a pair of 2A3 tubes in push-pull, or 6B4G equivalents.

The proper choice of elements in the a.b.c. circuit results in maximum power output, minimum distortion, and highest efficiency. Under static or no-load conditions, the plate current of the two push-pull tubes is maintained at the desired value for good tube life. Under dynamic conditions or load up to maximum undistorted output, the plate current will rise substantially, but the grid voltage remains at its no-load value. As shown in Fig. 1, this is accomplished by transmitting the output tubes' plate current through this resistor as a control by passing it through a d-c amplifier, and taking the output of this amplifier to automatically control the voltage applied to the grid-bias circuit of the push-pull output tubes.

The pilot resistor, R_s , is connected to the midpoint of the filament winding so that the plate current of the two output tubes flows through it. The voltage across this pilot resistor is impressed between the cathode and the d-c amplifier tube.

The resistor network through which the plate current of V_1 is fed is of high resistance, so the plate voltage is approximately the grid voltage multiplied by the μ of the tube. The grid voltage of V_2 is intermediate between the variable positive voltage of the plate of the first tube, and the fixed negative voltage derived from the power supply.

In this manner, the grid of V_2 is maintained at a negative voltage, which is desirable, and yet directly coupled to the plate of V_1 , which is at a positive voltage.

The tube V_1 and the resistor network R_{21} , R_{22} , and R_{23} , form a similar d-c amplifier stage. The output is conducted by the a.b.c. control line to the center tap of the secondary of the interstage transformer, substantially unchanged by the cathode driver to the output tubes' grids, thus controlling the output tube plate currents.

In operation, as the bias on the grids of the push-pull output tubes is made more negative by the a.b.c., the plate current of these tubes is reduced to a value at which the system finds equilibrium.

When a signal is impressed on the amplifier the plate currents vary as shown in Fig. 2. For small signals, the change in the total average plate current is negligible. For large signals, the total current increases twice per signal cycle, and for very large signals, each tube alternately goes completely to cutoff, and the current flows through only one tube during part of a signal cycle. But for short periods during the signal cycle when the signal voltage is crossing the zero axis, the plate current of each tube is very close to its zero signal value, as is the sum of the plate currents.

For best operation, it is desirable that the instantaneous minimum of the sum of the plate currents be held substantially constant at the zero signal value. This a-b-c circuit is therefore designed to utilize this instantaneous minimum of plate current as the control factor in setting the grid bias, and is substantially unaffected by changes in the average current due to increases in the plate current which occur during the signal cycle.

When a small signal is impressed, the average current through the tubes, and therefore, through the pilot resistor, does not change. (Class A operation.)

When a large signal is impressed, the total plate current rises, as shown in the fourth curve of *Fig. 2*, increasing the negative voltage on the grid of V_{1a} in respect to its cathode, and the plate of V_2 voltage tends to rise. But you will note there is a condenser, C_{27} , which is shunted from the plate of V_1 to ground. This condenser and R_{18} , which is of a very high value, control the time constant of this circuit. So as the grid of V_1 becomes more negative, the voltage of its plates cannot change instantaneously but rises slowly at a rate determined by C_{27} and R_{28} .

Until the plate voltage of V_1 reaches a value approximately μ times the grid-cathode bias, no plate current flows, and the current flowing through R_{18} and R_{17} results in a voltage being impressed on the grid of V_2 as stated before, which varies proportionately to the plate voltage of V_1 , but negative relative

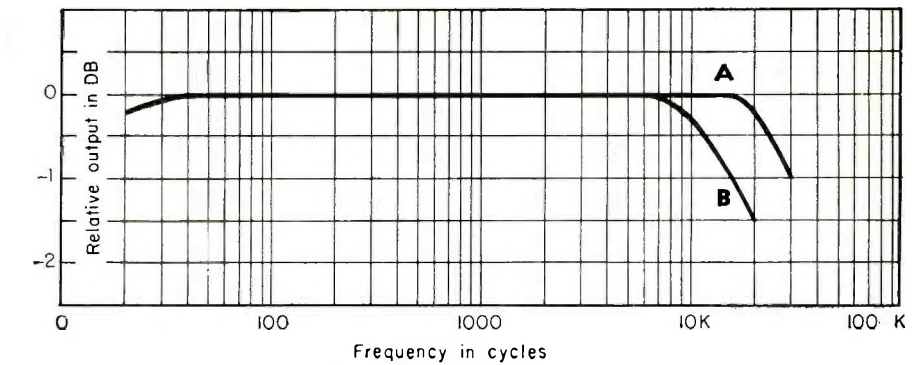

Fidelity response curve of high-quality amplifier. In (A), output power is one watt. Curve (B) shows response when the power output is 30 watts.

cycle, and so before the voltage builds up appreciably, the signal approaches the zero axis, the plate current of the output tube drops to its zero signal value, and the grid bias on V_1 drops to its zero value. The plate of V_1 again conducts and discharges C_{27} , down to its original voltage corresponding to zero signal as shown in the last curve of *Fig. 2*. As the charge on condenser C_{27} has too short an interval to build up its voltage appreciably, its average voltage remains substantially at the value for zero signal and does not change appreciably when the signal increases from zero to a very large value. The plate voltage of V_1 , impressed on the voltage divider formed by resistors R_{18} and R_{17} results in a voltage being impressed on the grid of V_2 as stated before, which varies proportionately to the plate voltage of V_1 , but negative relative

thereto, so the grid of V_2 is negative.

The result is the plate voltage of V_2 varies with that of V_1 , but in opposite sense, and in larger amounts due to the amplification of V_2 . Similarly, the plate voltage of V_2 , impressed on the voltage divider R_{28} and R_{25} , results in a voltage known as the bias control to the amplifier output tubes. This a-b-c voltage varies proportionately with the voltage on the plate V_{1a} but negative. The a.b.c. is directly controlled by the instantaneous minimum of total plate current of the output tubes, which is the desired condition for maximum power output and minimum distortion, the highest efficiency.

Transients

Transient response cannot be neglected in a high-quality system. [Continued on page 41]

Fig. 4. Complete schematic of the Brook high-quality amplifier. Special interstage transformers are required.

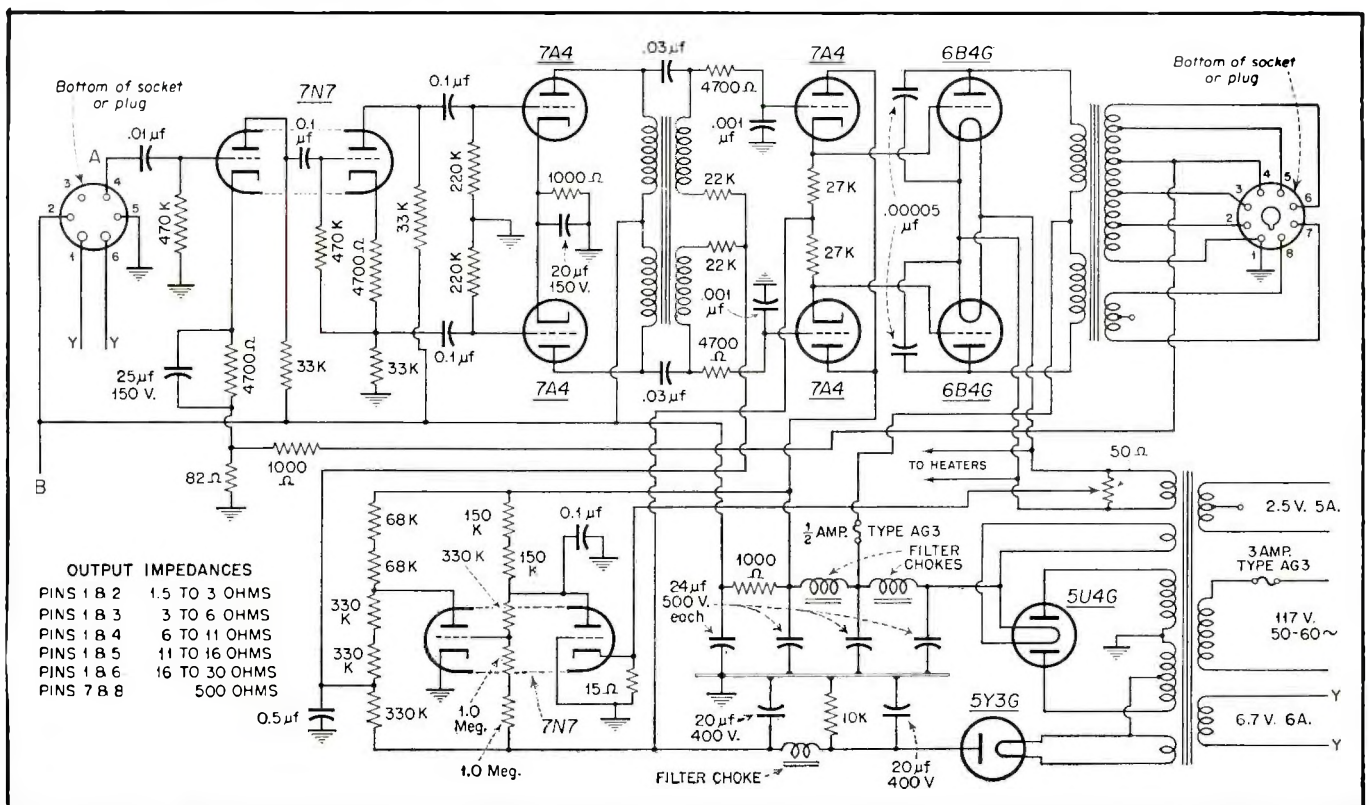

Audio Amplifier

[from page 9]

Transient waveforms should be transmitted without distortion since audible sounds have very important transient characteristics. Percussion instruments and staccato scores on the brasses demand good transient response. A square wave introduced into an amplifier and viewed on a scope is a good test for transient responses. *Fig. 3* shows a 5000-cycle square wave through this amplifier.

Good transient response is accomplished by extending the frequency range and having negligible phase shift between input and output of an amplifier.

Transformer resonance can cause slight oscillations well above the audible range. If the phase shift at these oscillation frequencies is sufficient to cause the feedback to become positive, regeneration will take place, resulting in sustained oscillations and overloading of the amplifier at super-audible frequencies. This can be avoided by reducing the gain of the amplifier above the useful frequency range, or by preventing the occurrence of these oscillations by proper design of the output transformer.

The transformers are completely free from saturation or leakage reactance effects from 25 to 20,000 cycles at any power up to maximum output. The low frequency response is flat within 2 db to 3 cycles. The extremely low frequency response in the amplifier is attenuated in the first stage to eliminate the effects of transients in tuning a radio receiver, or phonograph turntable eccentricity, or rumble. Some amplifiers for industrial application have made use of this good low frequency response. The low-frequency attenuation is accomplished by using a condenser in series with the input to the grid of the first tube. The complete schematic is shown in *Fig. 4*.

The output transformer is largely responsible for the line performance of the amplifier. It looks like a simple end-bell type of transformer, but with larger-than-usual output transformers. The amount of iron in the transformer and the unique, very complicated wind structure gives the transformer no frequency discrimination and negligible phase shift over the entire audio range.

Negative Feedback

Everything possible was done to produce a perfect audio amplifier without using feedback. After this was accomplished, 11 db of feedback was added. This amplifier without feedback has as good a frequency response as usual high-fidelity amplifiers with feedback. In

other words, it does not depend entirely upon feedback for its 0.2 db variation from 20 to 20,000 cycles.

The input impedance to the amplifier is normally 0.5 megohms. An input transformer is hermetically sealed. It is well shielded from magnetic pickup by having three nickel alloy shields. The leads pick up more hum than the transformer.

Power is available for operating additional preamplifiers or a tuner. The voltages available are 6.6 volts at 5.5 amps, and 300 volts at 90 ma, d.c.

The distortion at full output of 30 watts is less than 2½ per cent. The intermodulation distortion, or double-frequency results, are extremely low. Taken at 24 watts at 50 cycles and 1.5 watts at 1000 cycles, the intermodulation distortion is 1.7 per cent. Taken at 4.7 watts at 50 cycles and 0.3 watts at 1000 cycles, the intermodulation distortion is 0.2 per cent, referred to the 1000-cycle signal.

Listening tests carried out in conjunction with a wide-range loudspeaker system have fully supported the measured performance. We could not detect distortion in reproducing organ music including 25-cycle pedal notes. It provides an ideal amplifier for sound-recording purposes, FM monitoring or anywhere else where distortionless amplification is necessary.