

LOUDSPEAKER SYSTEM

ZgB 60-8-594 (VOYAGER SAT.) 9 6111 167 04 , 05

TECHNICAL DATA

System type	bass reflex
Rated impedance	8 Ω
Rated frequency range	80 - 25000 Hz
Rated input power	60 W
Max. input power	80 W
Sensitivity	86 dB
Crossover frequencies	2 kHz
Loudspeakers:	

GDN 13/50/8 - 8 Ω
GDWK 8,5/50 - 8 Ω

Dimensions
Mass

175 x 250 x 170 mm
3,5 kg

Finish: PVC

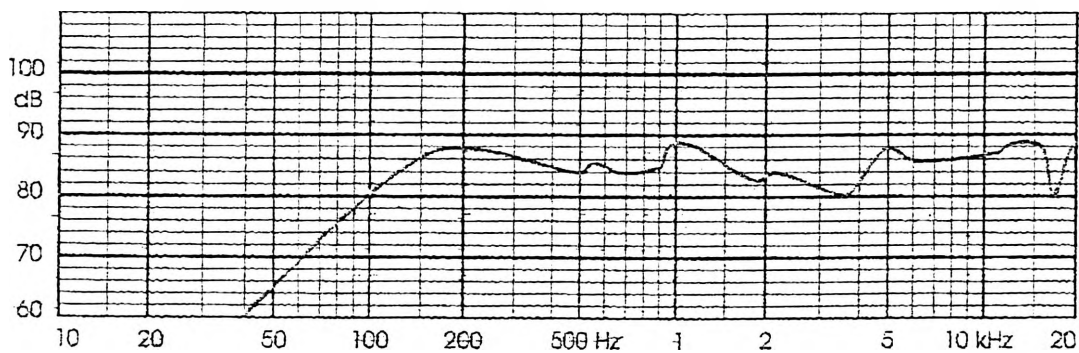
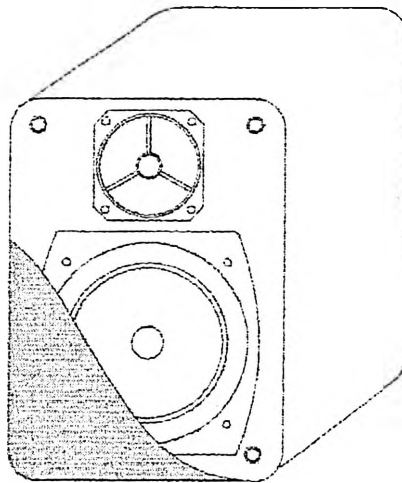

FREQUENCY RESPONSE CURVE

Measured in anechoic room at 1W, 1m, free field.

LOUDSPEAKER SYSTEM

ZgB 60-8-594 (VOYAGER SAT.) 9 6111 167 04 , 05

INDEKSY PODZESPOŁÓW SERWISOWYCH

GDN 13/50/8 - 8 ohm
GDWK 8,5/50 - 8 ohm
Zwrotnica elektryczna

9 5151 275 15
8 5155 101 02
9 5291 144 17

8 4171 317 01

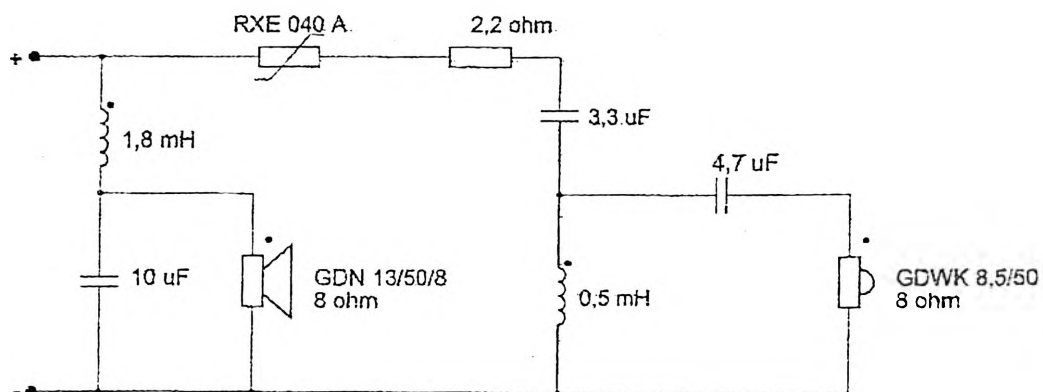

SCHEMAT ZWROTNICY ELEKTRYCZNEJ