

632-387

GL494 PWM CONTROL CIRCUIT

Description

The GL494 incorporates on a single monolithic chip all the functions required in the construction of a pulse-width-modulation control circuit. Designed primarily for power supply control, the GL494 contains an on-chip 5-volt regulator, two error amplifiers, adjustable oscillator, dead-time control comparator, pulse-steering flip-flop, and output control circuitry. The uncommitted output transistors provide either common-emitter or emitter-follower output capability. Push-pull or single-ended output operation may be selected through the output-control function. The architecture of the GL494 prohibits the possibility of either output being pulsed twice during push-pull operation.

Features

- Complete PWM Power Control Circuitry
- Uncommitted Outputs for 200 mA Sink or Source
- Output Control Selects Single-Ended or Push-Pull Operation
- Internal Circuitry Prohibits Double Pulse at Either Output
- Internal Regulator Provides a Stable 5V Reference Supply
- Variable Dead-Time Provides Control Over Total Range

Block Diagram

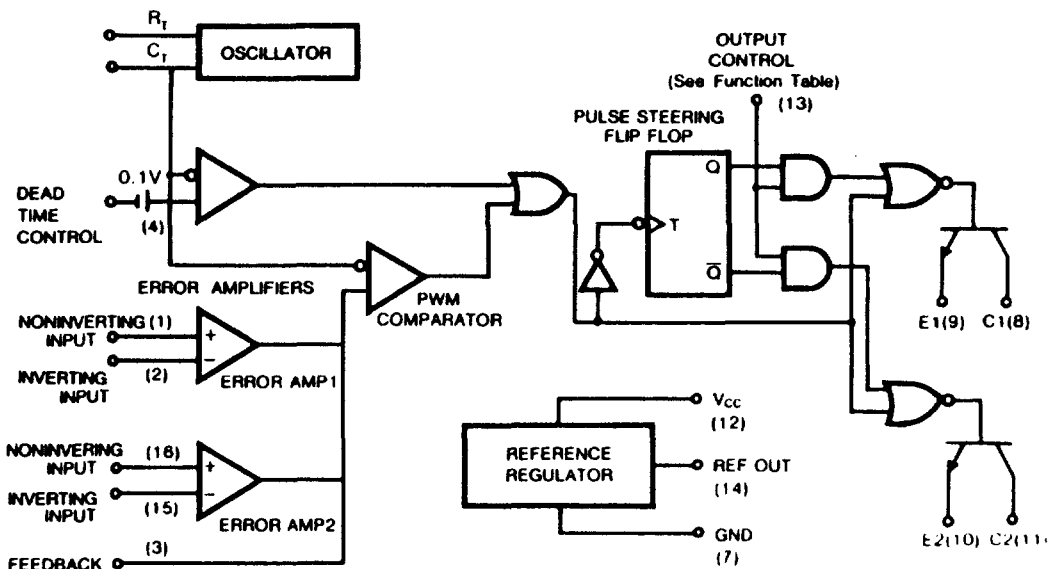

Pin Configuration

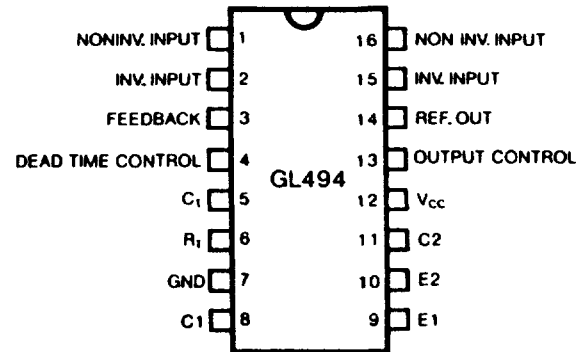

Function Table

Output Control	Output Function
Grounded	Single-ended or Parallel Output
At V_{ref}	Normal Push-Pull Operation

Absolute Maximum Ratings

Supply Voltage, V_{CC}	41	V
Amplifier Input Voltage	$V_{CC}+0.3$	V
Collector Output Voltage	41	V
Continuous Total dissipation at (or below) 25°C	1000	mW
Operating Free-Air Temperature Range	-20 to 85	°C
Storage Temperature Range	-65 to 150	°C
Collector Output Current	250	mA

Recommended Operation Conditions

PARAMETER	MIN	MAX	UNIT
Supply Voltage, V_{CC}	7	40	V
Amplifier Input Voltage, V_i	-0.3	$V_{CC}-2$	V
Collector Output Voltage, V_O		40	V
Collector Output Current (Each Transistor)		200	mA
Current Into Feed back Terminal		0.3	mA
Timing Capacitor, C_T	0.47	10,000	nF
Timing Resistor, R_T	1.8	500	KΩ
Oscillator Frequency	1	300	KHz
Operating Free-Air Temperature	-20	85	°C

Electrical Characteristics (Temperature -20~85°C, $V_{CC}=15V$, $f=10KHz$)

Reference Section

PARAMETER	TEST CONDITIONS	MIN	TYP(1)	MAX	UNIT
Output voltage (V_{ref})	$I_O=1\text{ mA}$	4.75	5	5.25	V
Input regulation	$V_{CC}=7V\text{ to }40V$, $T_A=25^\circ\text{C}$		2	25	mV
Output regulation	$I_O=1\text{ to }10\text{mA}$, $T_A=25^\circ\text{C}$		1	15	mV
Output Voltage change with temperature	$T_A=-20^\circ\text{C to }85^\circ\text{C}$		0.2	1	%
Short-circuit output current(2)	$V_{ref}=0$		35		mA

Oscillator Section

PARAMETER	TEST CONDITIONS	MIN	TYP(1)	MAX	UNIT
Frequency	$C_T=0.01\mu\text{F}$ $R_T=12\text{k}\Omega$		10		KHz
Standard deviation of frequency (3)	All values of V_{CC} , C_T , R_T , T_A Constant		10		%
Frequency change with voltage	$V_{CC}=7V\text{ to }40V$, $T_A=25^\circ\text{C}$		0.1		%
Frequency change with temperature	$C_T=0.01\mu\text{F}$, $R_T=12\text{k}\Omega$ $T_A=-20^\circ\text{C to }85^\circ\text{C}$			2	%

Dead Time Control Section

PARAMETER	TEST CONDITIONS	MIN	TYP(1)	MAX	UNIT
Input bias current (pin 4)	$V_I=0$ to 5.25V		-2	-10	μA
Maximum duty cycle, each output	$V_{I(\text{pin } 4)}=0\text{V}$	45			%
Input threshold voltage (pin 4)	Zero duty cycle		3	3.3	V
	Maximum duty cycle	0			V

Error Amp Sections

PARAMETER	TEST CONDITIONS	MIN	TYP(1)	MAX	UNIT
Input offset voltage	$V_{O(\text{PIN}3)}=2.5\text{V}$		2	10	mV
Input offset current	$V_{O(\text{PIN}3)}=2.5\text{V}$		25	250	nA
Input bias current	$V_{O(\text{PIN}3)}=2.5\text{V}$		0.2	1	μA
Common-mode input voltage range	$V_{CC}=7\text{V}$ to 40V	LOW	-0.3		V
		HIGH	$V_{CC}-2$		
Open-loop voltage amplification	$\Delta V_O=3\text{V}$, $V_O=0.5$ to 3.5V	70	95		dB
Unity-gain bandwidth			800		KHz
Common-mode rejection ratio	$V_{CC}=40\text{V}$, $T_A=25^\circ\text{C}$	65	80		dB
Output sink current (pin 3)	$V_{ID}=-15\text{mV}$ to -5V, $V_{O(\text{pin } 3)}=0.7\text{V}$	0.3	0.7		mA
Output source current (pin 3)	$V_{ID}=15\text{mV}$ to 5V, $V_{O(\text{pin } 3)}=3.5\text{V}$	-2			mA

PWM Comparator Section

PARAMETER	TEST CONDITIONS	MIN	TYP(1)	MAX	UNIT
Input threshold voltage (pin 3)	Zero duty cycle		4	4.5	V
Input sink current (pin 3)	$V_{O(\text{PIN}3)}=0.7\text{V}$	0.3	0.7		mA

Switching Characteristics

PARAMETER	TEST CONDITIONS	MIN	TYP(1)	MAX	UNIT
Output voltage rise time	Common-emitter configuration, See Test Circuit 3		100	200	ns
Output voltage fall time				25	100
Output voltage rise time	Emitter-follower configuration, See Test Circuit 4		100	200	ns
Output voltage fall time				40	100

Output Section

PARAMETER		TEST CONDITIONS	MIN	TYP(1)	MAX	UNIT
Collector off-state current		$V_{CE}=40V, V_{CC}=40V$		2	100	μA
Emitter off-state current		$V_{CC}=V_C=40V, V_E=0$			-100	μA
Collector-emitter saturation voltage	Common-emitter	$V_E=0, I_C=200mA$		1.1	1.3	V
	Emitter-follower	$V_C=15V, I_E=-200mA$		1.5	2.5	
Output control input current		$V_I=V_{ref}$			3.5	mA

Total Device

PARAMETER	TEST CONDITIONS	MIN	TYP(1)	MAX	UNIT	
Standby supply current	All other inputs & outputs open	$V_{CC}=15V$		6	10	mA
		$V_{CC}=40V$		9	15	mA
Average supply current	$V_{(pin\ 4)}=2V,$ See Test Circuit 1		7.5		mA	

Notes:

- (1) All typical values except for temperature coefficients are at $T_A=25^\circ$
- (2) Duration of the short circuit should not exceed one second.
- (3) Standard deviation is a measure of the statistical distribution about the mean as derived from the formula

$$\sigma = \sqrt{\frac{\sum_{n=1}^N (X_n - \bar{X})^2}{N-1}}$$

Parameter Measurement Information

1. Dead time and Feedback Control

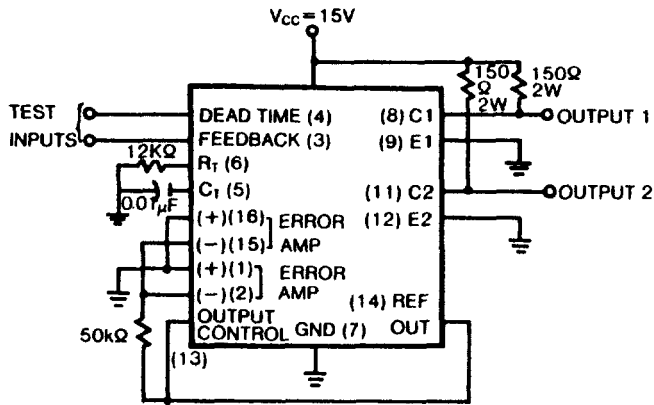

TEST CIRCUIT

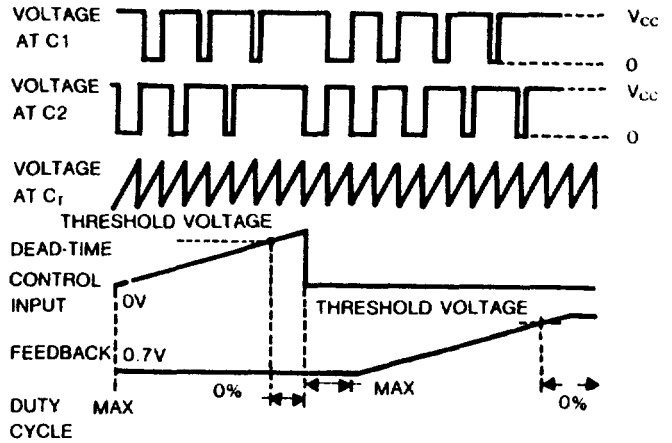

VOLTAGE WAVEFORMS

2. Error Amplifier Characteristics

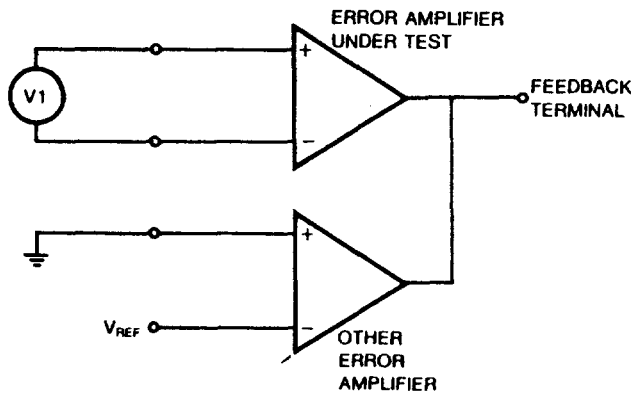

3. Common-Emitter Configuration

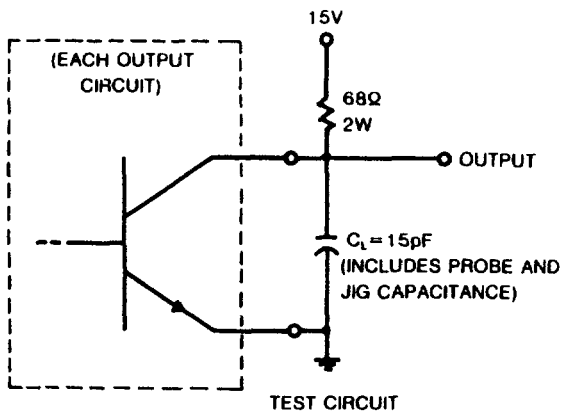

TEST CIRCUIT

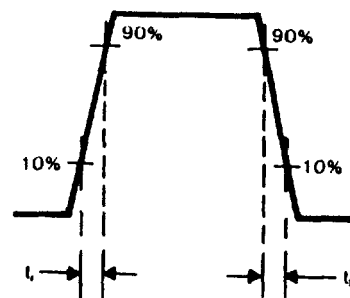

OUTPUT VOLTAGE WAVEFORM

4. Emittre-Follower Configuration

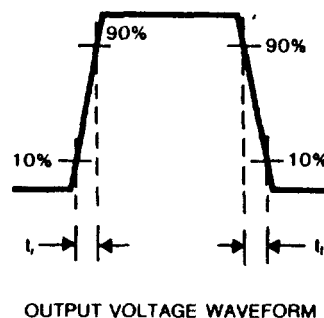
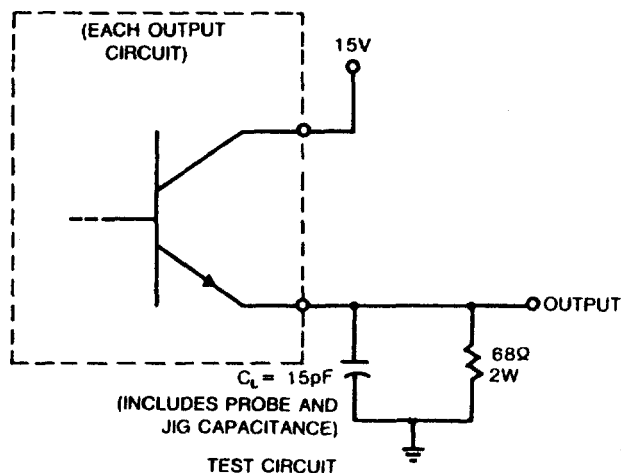

Typical Performance Curves

FIGURE 1 - OSCILLATOR FREQUENCY versus TIMING RESISTANCE

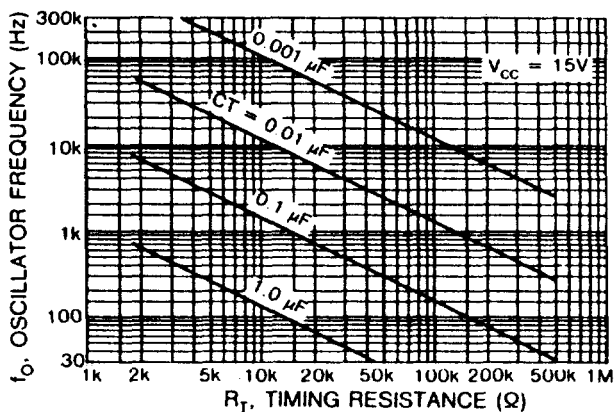

FIGURE 2 - OPEN LOOP VOLTAGE GAIN AND PHASE versus FREQUENCY

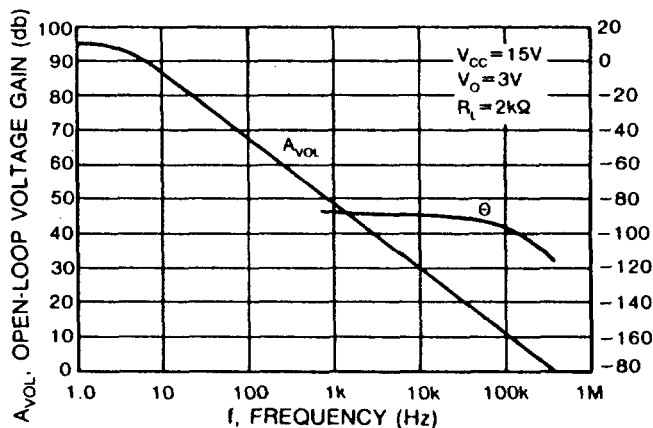

FIGURE 3 - PERCENT DEAD TIME versus OSCILLATOR FREQUENCY

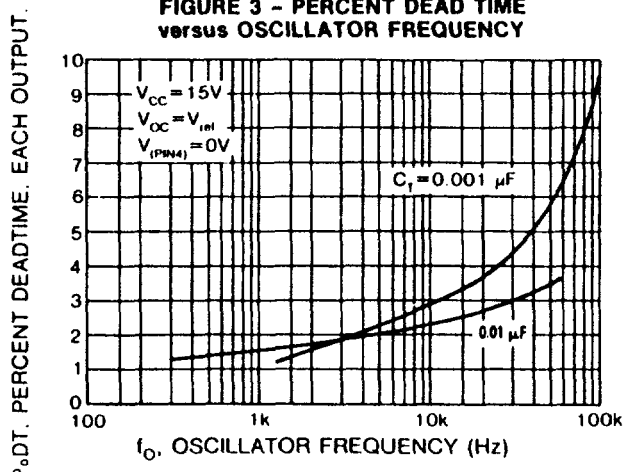
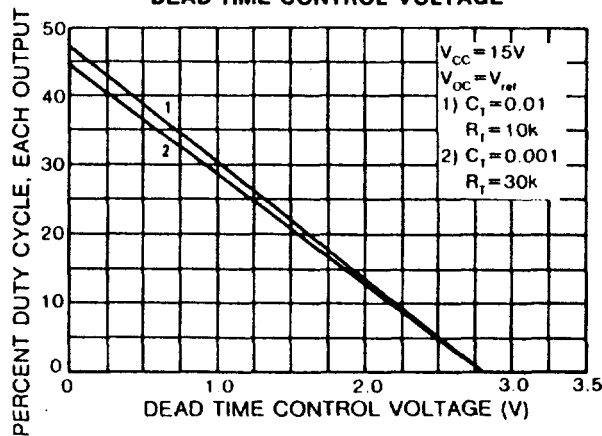
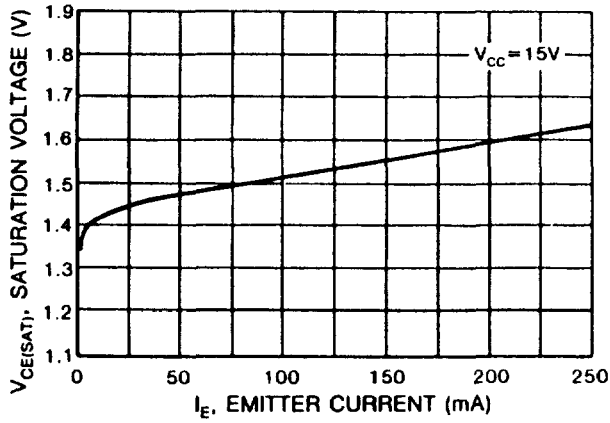

FIGURE 4 - PERCENT DUTY CYCLE versus DEAD-TIME CONTROL VOLTAGE



**FIGURE 5 - EMITTER-FOLLOWER CONFIGURATION,
OUTPUT-SATURATION VOLTAGE
versus EMITTER CURRENT**



**FIGURE 6 - COMMON-EMITTER CONFIGURATION
OUTPUT-SATURATION VOLTAGE
versus COLLECTOR CURRENT**

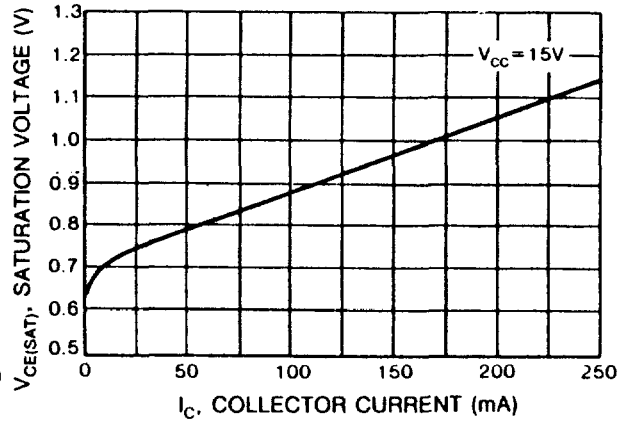

**FIGURE 7 - STANDBY-SUPPLY CURRENT
versus SUPPLY VOLTAGE**

