



IRAMX16UP60A

iMOTION™ Series

16A, 600V

Plug N Drive™ Integrated Power Module for Appliance Motor Drive

Description

International Rectifier's IramX16UP60A is an Integrated Power Module developed and optimized for electronic motor control in appliance applications such as washing machines and variable speed compressor drives for in-room air-conditioning systems and commercial refrigerators. Plug N Drive technology offers an extremely compact, high performance AC motor-driver in a single isolated package for a very simple design. An open emitter configuration of the low side IGBT switches offer easy current feedback and overcurrent monitor for high precision and reliable control.

A built-in temperature monitor and over-current protection, along with the short-circuit rated IGBTs and integrated under-voltage lockout function, deliver high level of protection and fail-safe operation.

The integration of the bootstrap diodes for the high-side driver section, and the single polarity power supply required to drive the internal circuitry, simplify the utilization of the module and deliver further cost reduction advantages.

Features

- Integrated Gate Drivers and Bootstrap Diodes.
- Temperature Monitor
- Temperature and Overcurrent shutdown
- Fully Isolated Package.
- Low VCE (on) Non Punch Through IGBT Technology.
- Undervoltage lockout for all channels
- Matched propagation delay for all channels
- Low side IGBT emitter pins for current control
- Schmitt-triggered input logic
- Cross-conduction prevention logic
- Lower di/dt gate driver for better noise immunity
- Motor Power range 0.75~2kW / 85~253 Vac
- Isolation 2000V_{RMS} min



Absolute Maximum Ratings

Parameter	Description	Max. Value	Units
V _{CES}	Maximum IGBT Blocking Voltage	600	V
I _o @ T _C =25°C	RMS Phase Current	16	A
I _o @ T _C =100°C	RMS Phase Current	8	
I _{pk}	Maximum Peak Phase Current (tp<100ms)	30	
F _p	Maximum PWM Carrier Frequency	20	KHz
P _d	Maximum Power dissipation per Phase	35	W
V _{iso}	Isolation Voltage (1min)	2000	V _{RMS}
T _J (IGBT & Diodes)	Operating Junction temperature Range	-40 to +150	°C
T _J (Driver IC)	Operating Junction temperature Range	-40 to +150	
T	Mounting torque Range (M3 screw)	0.8 to 1.0	Nm

Internal Electrical Schematic - I RAMX16UP60A

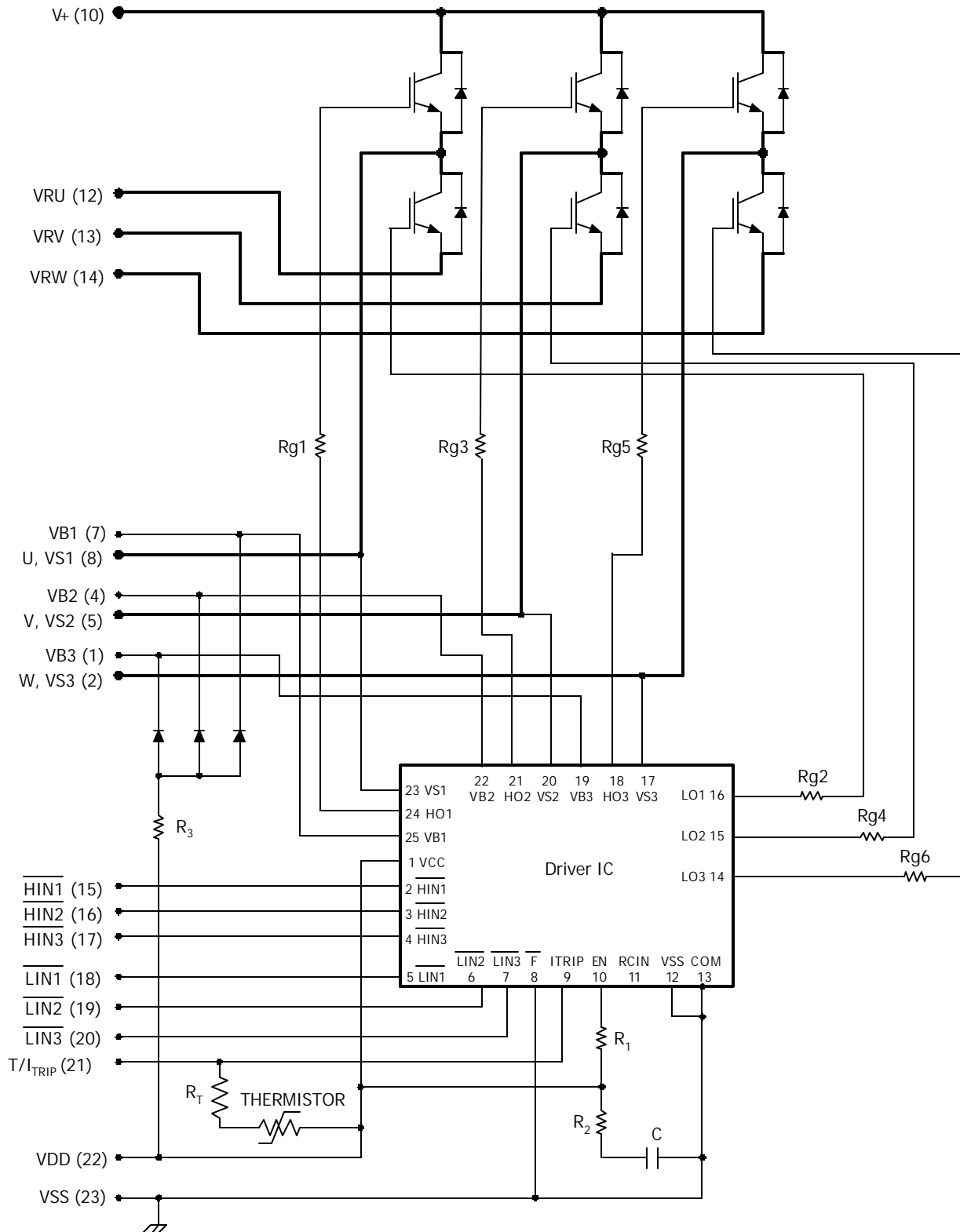

Inverter Section Electrical Characteristics @ $T_J = 25^\circ\text{C}$

Symbol	Parameter	Min	Typ	Max	Units	Conditions
$V_{(BR)CES}$	Collector-to-Emitter Breakdown Voltage	600	---	---	V	$V_{IN}=5V, I_C=20mA$
$\Delta V_{(BR)CES} / \Delta T$	Temperature Coeff. Of Breakdown Voltage	---	0.3	---	V/°C	$V_{IN}=5V, I_C=1.0mA$ ($25^\circ\text{C} - 150^\circ\text{C}$)
$V_{CE(ON)}$	Collector-to-Emitter Saturation Voltage	---	1.55 1.75	1.75 2.00	V	$I_C=8A, T_J=25^\circ\text{C}, V_{DD}=15V$ $I_C=8A, T_J=150^\circ\text{C}$
I_{CES}	Zero Gate Voltage Collector Current	---	5 50	15 80	μA	$V_{IN}=5V, V^+=600V$ $V_{IN}=5V, V^+=600V, T_J=150^\circ\text{C}$
V_{FM}	Diode Forward Voltage Drop	---	2.0 1.5	3.25 2.0	V	$I_C=8A$ $I_C=8A, T_J=150^\circ\text{C}$

Inverter Section Switching Characteristics @ $T_J = 25^\circ\text{C}$

Symbol	Parameter	Min	Typ	Max	Units	Conditions	
E_{on}	Turn-On Switching Loss	---	315	435	μJ	$I_C=8A, V^+=400V$ $V_{DD}=15V, L=2mH$ $T_J=25^\circ\text{C}$	
E_{off}	Turn-Off Switching Loss	---	150	180			
E_{tot}	Total Switching Loss	---	465	615			
E_{on}	Turn-on Switching Loss	---	500	700	μJ	See CT1 $T_J=150^\circ\text{C}$ Energy losses include "tail" and diode reverse recovery	
E_{off}	Turn-off Switching Loss	---	255	310			
E_{tot}	Total Switching Loss	---	755	1010			
E_{rec}	Diode Reverse Recovery energy	---	45	95	μJ	$T_J=150^\circ\text{C}, V^+=400V, V_{DD}=15V,$ $I_F=8A, L=2mH$	
t_{rr}	Diode Reverse Recovery time	---	105	145	ns		
RBSOA	Reverse Bias Safe Operating Area	FULL SQUARE					$T_J=150^\circ\text{C}, I_C=8A, V_p=600V$ $V^+=480V, V_{DD}=+15V \text{ to } 0V$ See CT3
SCSOA	Short Circuit Safe Operating Area	10	---	---	μs	$T_J=150^\circ\text{C}, V_p=600V,$ $V^+=360V,$ $V_{DD}=+15V \text{ to } 0V$ See CT2	

Thermal Resistance

Symbol	Parameter	Min	Typ	Max	Units	Conditions
$R_{th(J-C)}$	Junction to case thermal resistance, each IGBT under inverter operation.	---	---	4.0	°C/W	Flat, greased surface. Heatsink compound thermal conductivity - 1W/mK
$R_{th(J-C)}$	Junction to case thermal resistance, each Diode under inverter operation.	---	5	5.5	°C/W	
$R_{th(C-S)}$	Thermal Resistance case to sink	---	0.1	---	°C/W	

Absolute Maximum Ratings Driver function

Absolute maximum ratings indicate sustained limits beyond which damage to the device may occur. All voltage parameters are absolute voltages referenced to V_{SS} . (Note 1)

Symbol	Definition	Min	Max	Units
V^+	High Side offset voltage	-0.3	600	V
$V_{B1,2,3}$	High Side floating supply voltage	-0.3	20	V
V_{DD}	Low Side and logic fixed supply voltage	-0.3	20	V
V_{IN}	Input voltage LIN, HIN, T/I _{TRIP}	-0.3	7	V
T_J	Junction Temperature	-40	150	°C

Recommended Operating Conditions Driver Function

The Input/Output logic timing diagram is shown in figure 1. For proper operation the device should be used within the recommended conditions. All voltage parameters are absolute referenced to V_{SS} . The V_S offset rating is tested with all supplies biased at 15V differential. (Note 1)

Symbol	Definition	Min	Max	Units
$V_{B1,2,3}$	High side floating supply voltage	V_S+12	V_S+20	V
$V_{S1,2,3}$	High side floating supply offset voltage	Note 2	450	
V_{DD}	Low side and logic fixed supply voltage	12	20	V
V_{ITRIP}	T/I _{TRIP} input voltage	V_{SS}	$V_{SS}+5$	
V_{IN}	Logic input voltage LIN, HIN	V_{SS}	$V_{SS}+5$	V

Static Electrical Characteristics Driver Function

V_{BIAS} (V_{CC} , $V_{BS1,2,3}$) = 15V unless otherwise specified. The V_{IN} and I_{IN} parameters are referenced to V_{SS} and are applicable to all six channels. (Note 1)

Symbol	Definition	Min	Typ	Max	Units
$V_{IN,th+}$	Positive going input threshold	---	---	3.0	V
$V_{IN,th-}$	Negative going input threshold	0.8	---	---	V
V_{CCUV+} V_{BSUV+}	V_{CC} and V_{BS} supply undervoltage Positive going threshold	10.6	11.1	11.6	V
V_{CCUV-} V_{BSUV-}	V_{CC} and V_{BS} supply undervoltage Negative going threshold	10.4	10.9	11.4	V
V_{CCUVH} V_{BSUVH}	V_{CC} and V_{BS} supply undervoltage $I_{lockout}$ hysteresis	---	0.2	---	V
I_{QBS}	Quiescent V_{BS} supply current	---	70	120	μA
I_{OCC}	Quiescent V_{CC} supply current	---	1.6	2.3	μA
I_{LK}	Offset Supply Leakage Current	---	---	50	μA
I_{IN+}	Input bias current (OUT=HI or OUT=LO)	---	120	---	μA
$V(T/I_{TRIP})$	T/I _{TRIP} threshold Voltage (OUT=HI or OUT=LO) (Note 3)	3.85	4.3	4.75	V

Dynamic Electrical Characteristics

$V_{DD} = V_{BS} = V_{BIAS} = 15V$, $I_o = 1A$, $V_D = 9V$, $PWM_{in} = 2kHz$, $V_{INON} = V_{IN,th+}$, $V_{INOFF} = V_{IN,th-}$
 $T_A = 25^\circ C$ unless otherwise specified.

Symbol	Definition	Min	Typ	Max	Units
T_{ON}	Input to output propagation turn-on delay time (see fig. 11)	-	470	-	ns
T_{OFF}	Input to output propagation turn-off delay time (see fig. 11)	-	615	-	ns
D_T	Dead Time	-	300	-	ns
I/T_{Trip}	T/I_{Trip} to six switch to turn-off propagation delay (see fig. 2)	-	750	-	ns
T_{FCLTRL}	Post I_{Trip} to six switch to turn-off clear time (see fig. 2)	-	9	-	ms

Internal NTC - Thermistor Characteristics

Parameter		Typ	Units	Conditions
R_{25}	Resistance	100 +/- 5%	k Ω	$T_C = 25^\circ C$
R_{125}	Resistance	2.522 + 17.3 % /- 14.9%	k Ω	$T_C = 125^\circ C$
B	B-constant (25-50 $^\circ C$)	4250 +/- 3%	k	$R_2 = R_1 e^{[B(1/T_2 - 1/T_1)]}$
Temperature Range		-40 / 125	$^\circ C$	
Typ. Dissipation constant		1	mW/ $^\circ C$	$T_C = 25^\circ C$

Note 1: For more details, see IR21365 data sheet

Note 2: Logic operational for V_S from COM-5V to COM+600V. Logic stata held for V_S from COM-5V to COM- V_{BS} . (please refer to DT97-3 for more details)

Thermistor Built-in IRAMX16UP60A

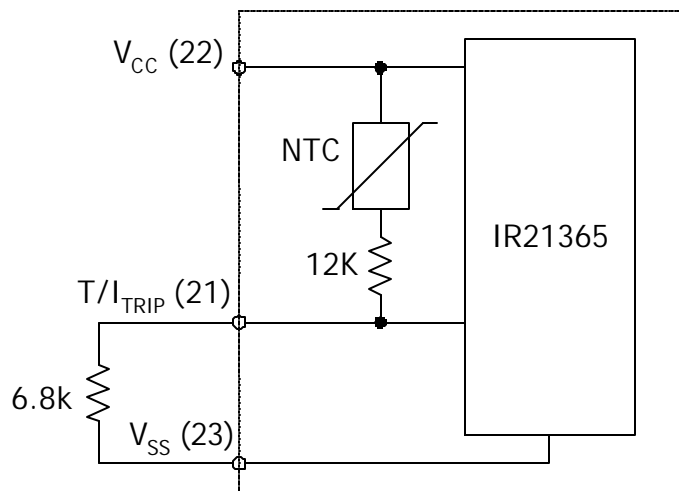

Note 3: The Maximum recommended sense voltage at the T/I_{TRIP} terminal under normal operating conditions is 3.3V.

IRAMX16UP60A

Figure1. Input/Output Timing Diagram

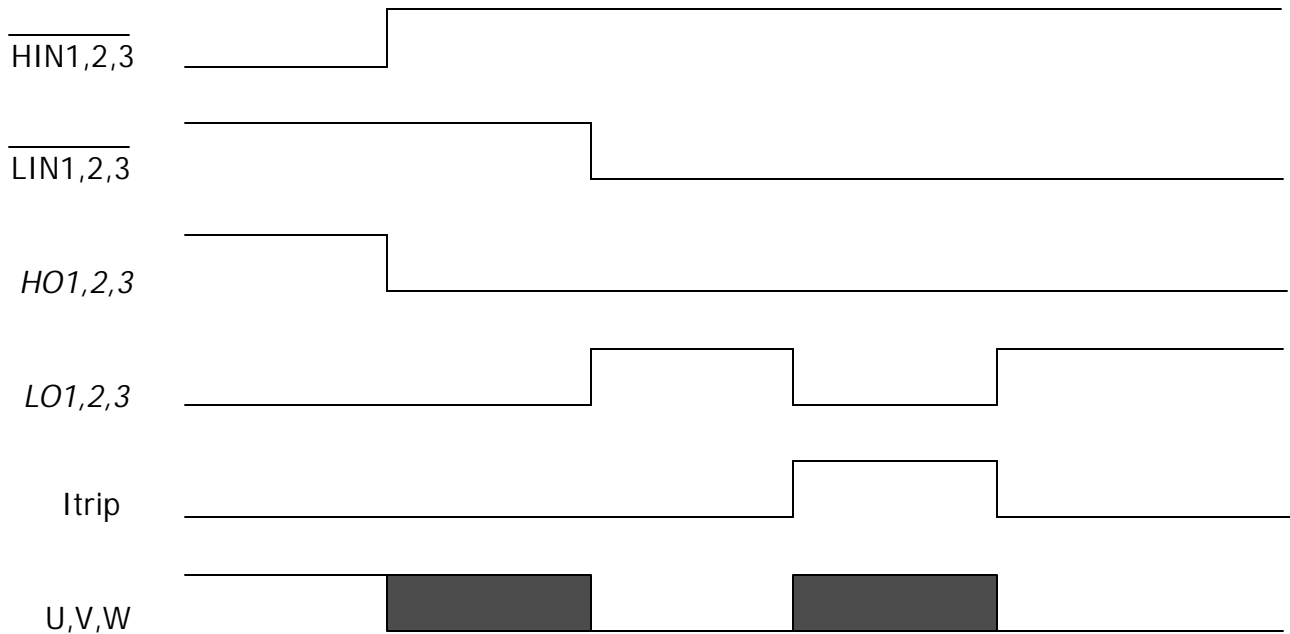

Note 4: The shaded area indicates that both high-side and low-side switches are off and therefore the half-bridge output voltage would be determined by the direction of current flow in the load.

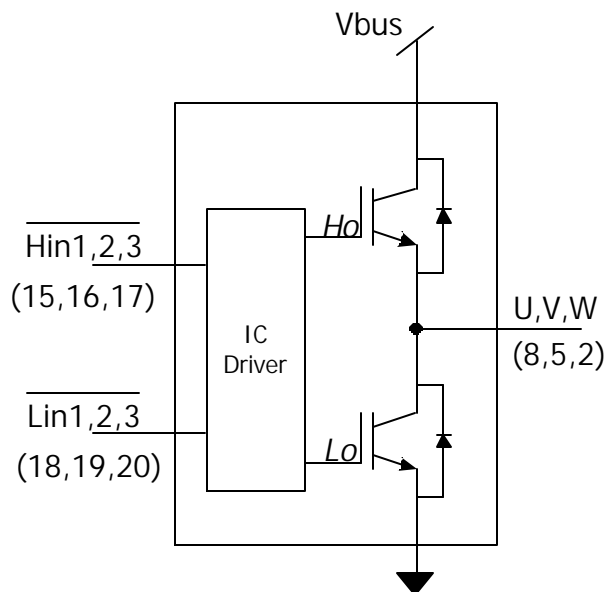

I_{trip}	$\overline{HIN1,2,3}$	$\overline{LIN1,2,3}$	U,V,W
0	0	1	V_{bus}
0	1	0	0
0	1	1	X
1	X	X	X

Figure 2. T/I_{Trip} Timing Waveform

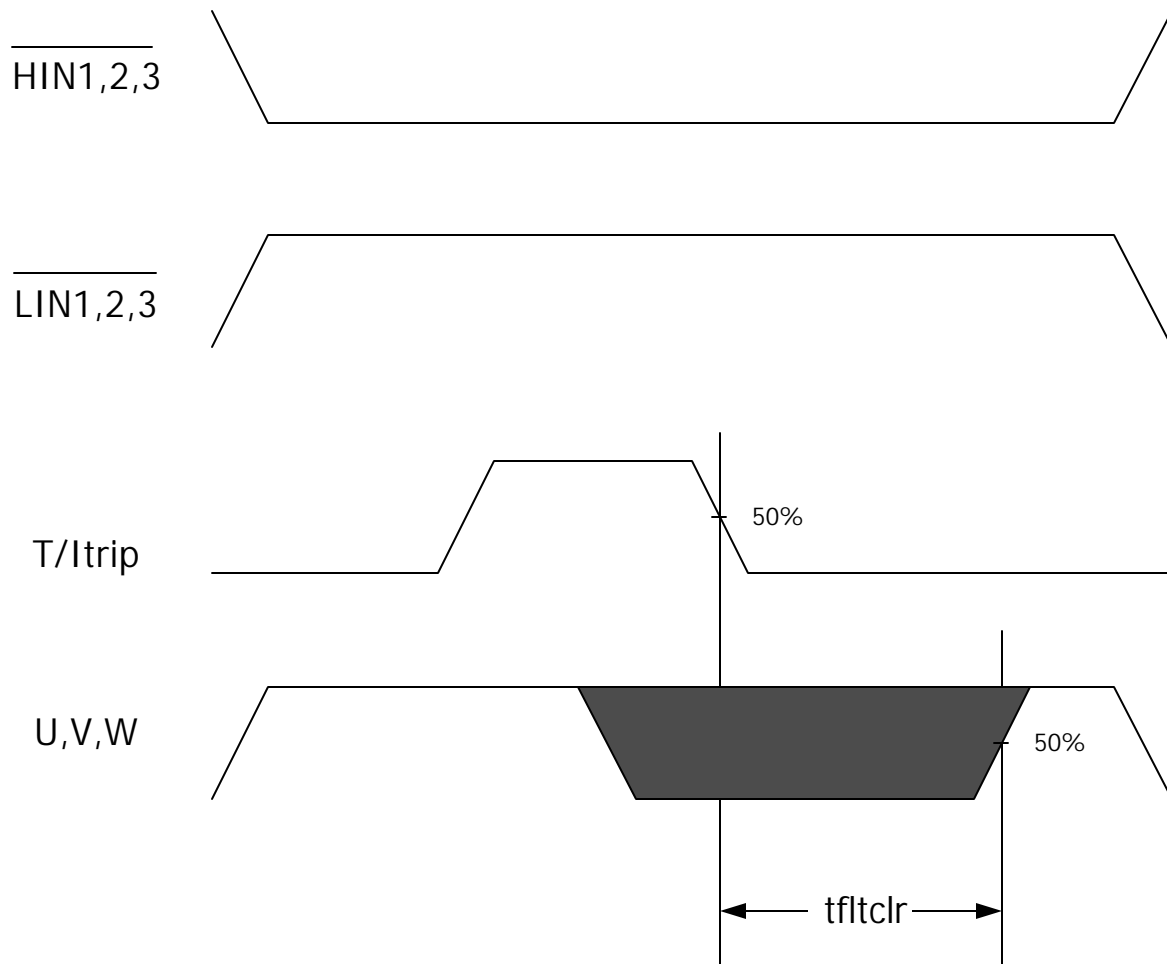

Note 5: The shaded area indicates that both high-side and low-side switches are off and therefore the half-bridge output voltage would be determined by the direction of current flow in the load.

Module Pin-Out Description

Pin	Name	Description
1	VB3	High Side Floating Supply Voltage 3
2	W, VS3	Output 3 - High Side Floating Supply Offset Voltage
3	na	none
4	VB2	High Side Floating Supply voltage 2
5	V, VS2	Output 2 - High Side Floating Supply Offset Voltage
6	na	none
7	VB1	High Side Floating Supply voltage 1
8	U, VS1	Output 1 - High Side Floating Supply Offset Voltage
9	na	none
10	V+	Positive Bus Input Voltage
11	na	none
12	LE1	Low Side Emitter Connection - Phase 1
13	LE2	Low Side Emitter Connection - Phase 2
14	LE3	Low Side Emitter Connection - Phase 3
15	HIN1	Logic Input High Side Gate Driver - Phase 1
16	HIN2	Logic Input High Side Gate Driver - Phase 2
17	HIN3	Logic Input High Side Gate Driver - Phase 3
18	LIN1	Logic Input Low Side Gate Driver - Phase 1
19	LIN2	Logic Input Low Side Gate Driver - Phase 2
20	LIN3	Logic Input Low Side Gate Driver - Phase 3
21	T/Itrip	Temperature Monitor and Shut-down Pin
22	VCC	+15V Main Supply
23	VSS	Negative Main Supply

Typical Application Connection IRAMX16UP60A

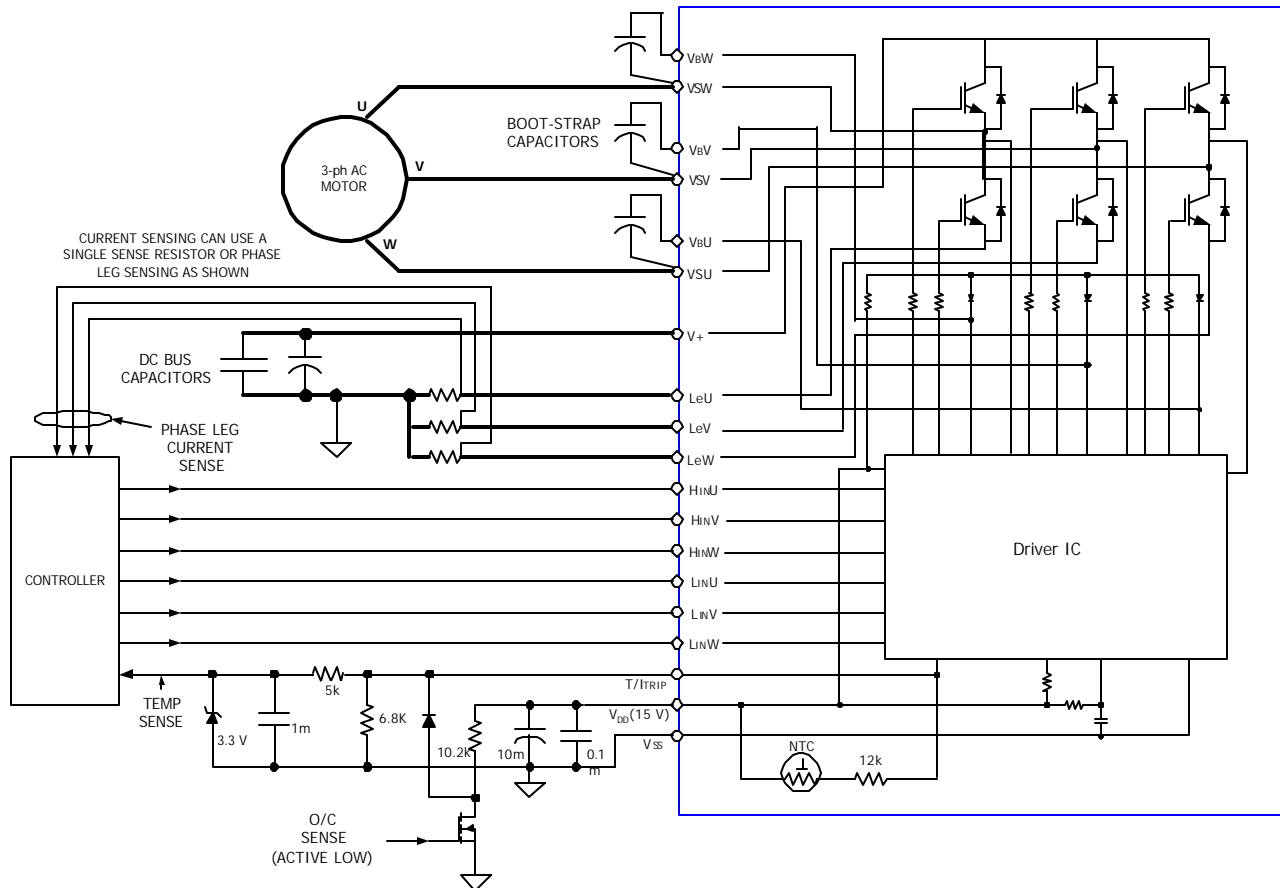

1. Electrolytic bus capacitors should be mounted as close to the module bus terminals as possible to reduce ringing and EMI problems. Additional high frequency ceramic capacitor mounted close to the module pins will further improve performance.
2. In order to provide good decoupling between Vcc-Gnd and Vb-Vs terminals, the capacitors shown connected between these terminals should be located very close to the module pins. Additional high frequency capacitors, typically 0.1mF, are strongly recommended.
3. Low inductance shunt resistors should be used for phase leg current sensing. Similarly, the length of the traces between pins 12, 13 and 14 to the corresponding shunt resistors should be kept as small as possible.
4. Value of the boot-strap capacitors depends upon the switching frequency. Their selection should be made based on IR design tip DN 98-2a or application note AN-1044.
5. Over-current sense signal can be obtained from external hardware detecting excessive instantaneous current in inverter.

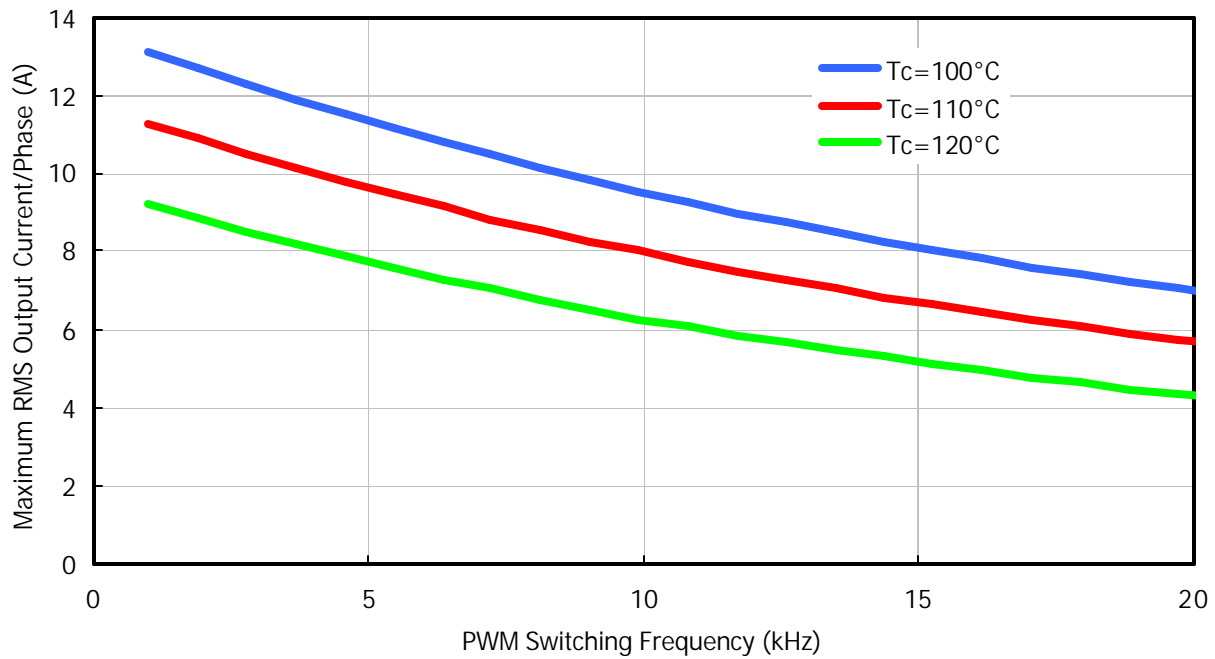

Figure 3. Maximum sinusoidal phase current as function of switching frequency
 $V_{BUS} =$, $T_j = 150^\circ\text{C}$, Modulation Depth=0.8, PF=0.6

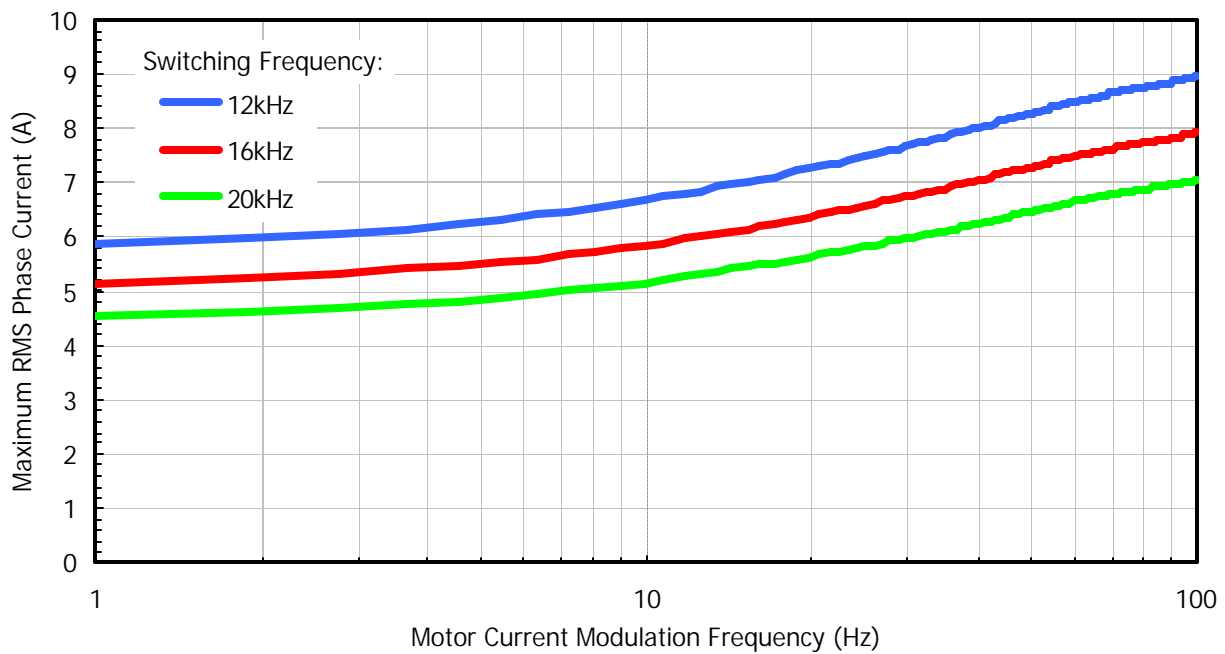

Figure 4. Maximum sinusoidal phase current as function of modulation frequency
 $V_{BUS} = 400\text{V}$, $T_j = 150^\circ\text{C}$, $T_c = 100^\circ\text{C}$, Modulation Depth=0.8, PF=0.6

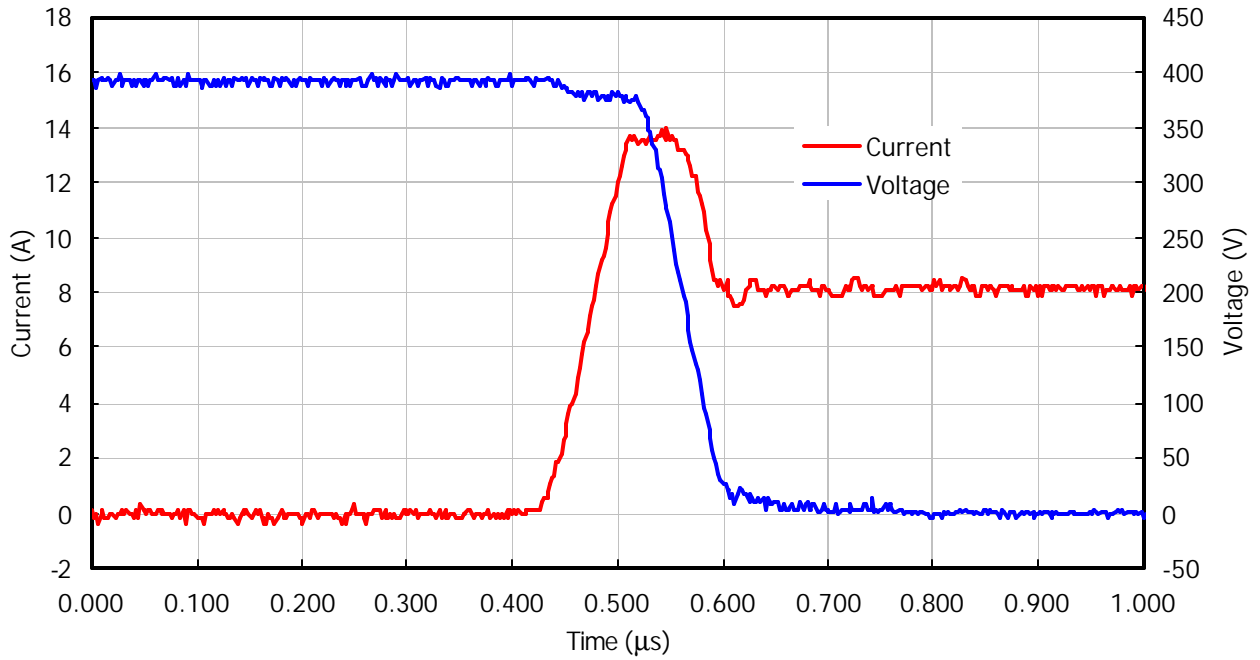

Figure 5. IGBT Turn-on. Typical turn-on waveform @ $T_j=150^{\circ}\text{C}$, $V_{\text{BUS}}=400\text{V}$

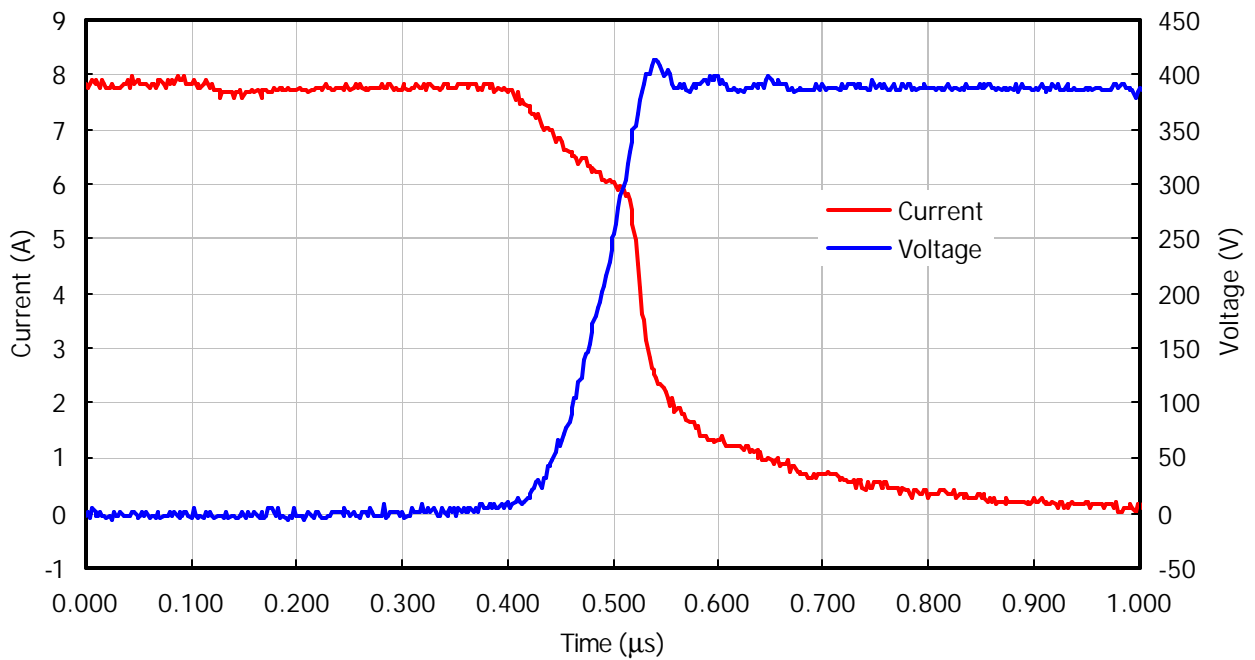

Figure 6. IGBT Turn-off. Typical turn-off waveform @ $T_j=150^{\circ}\text{C}$, $V_{\text{BUS}}=400\text{V}$

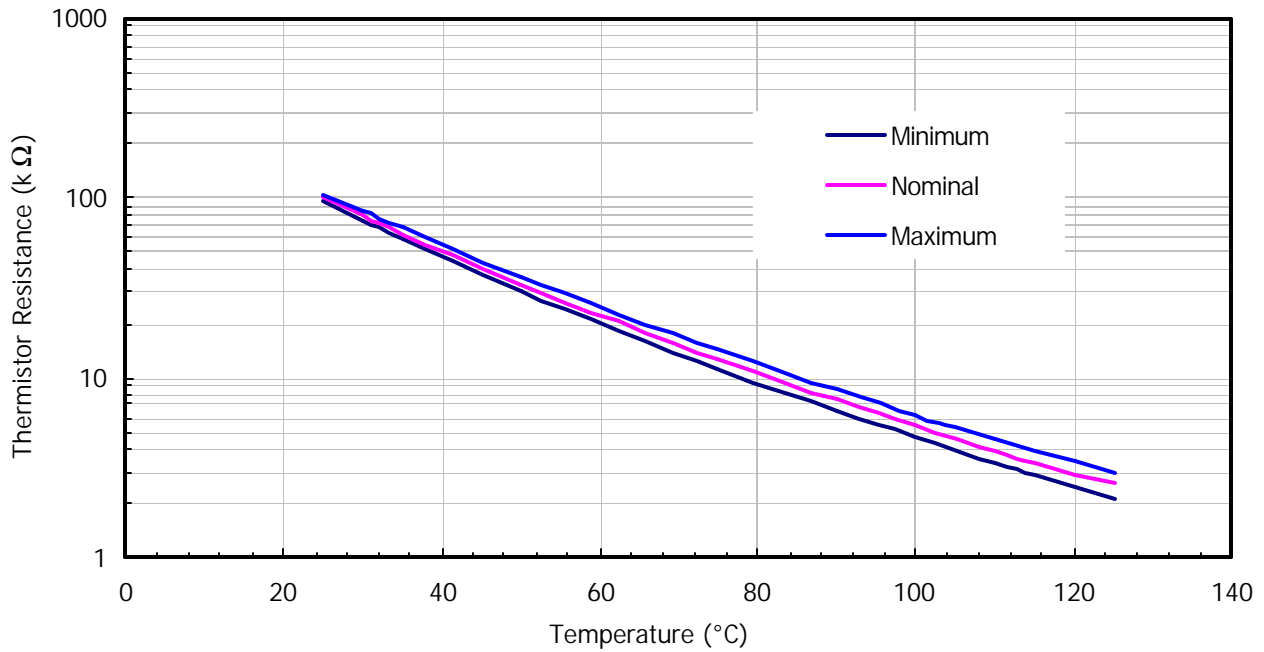

Figure 7. Variation of thermistor resistance with temperature

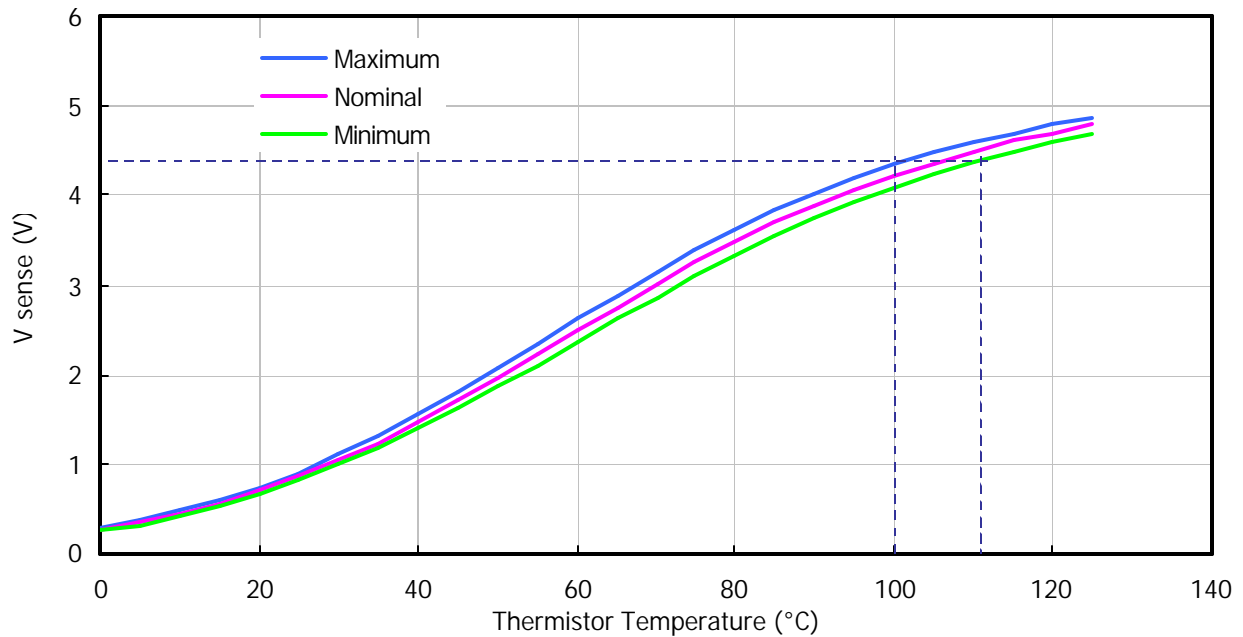

Figure 8. Variation of temperature sense voltage with thermistor temperature using external bias resistance of $6.8K\Omega$, $V_{CC}=15V$

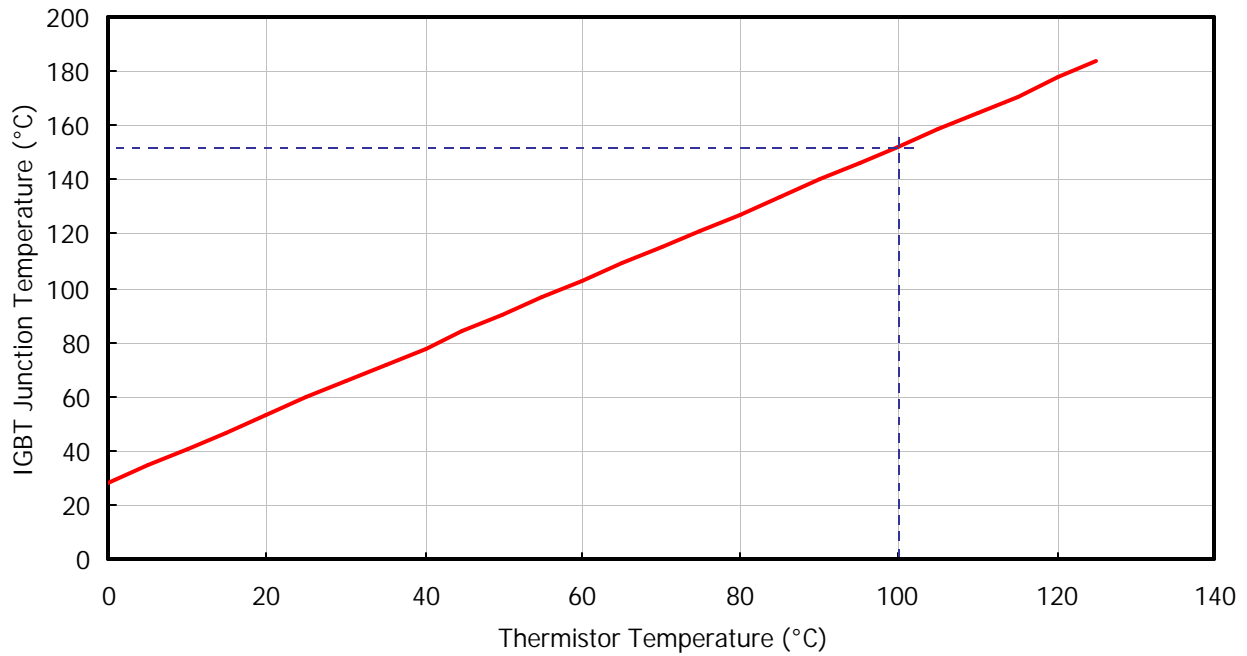

Figure 9. Estimated maximum IGBT junction temperature with thermistor temperature

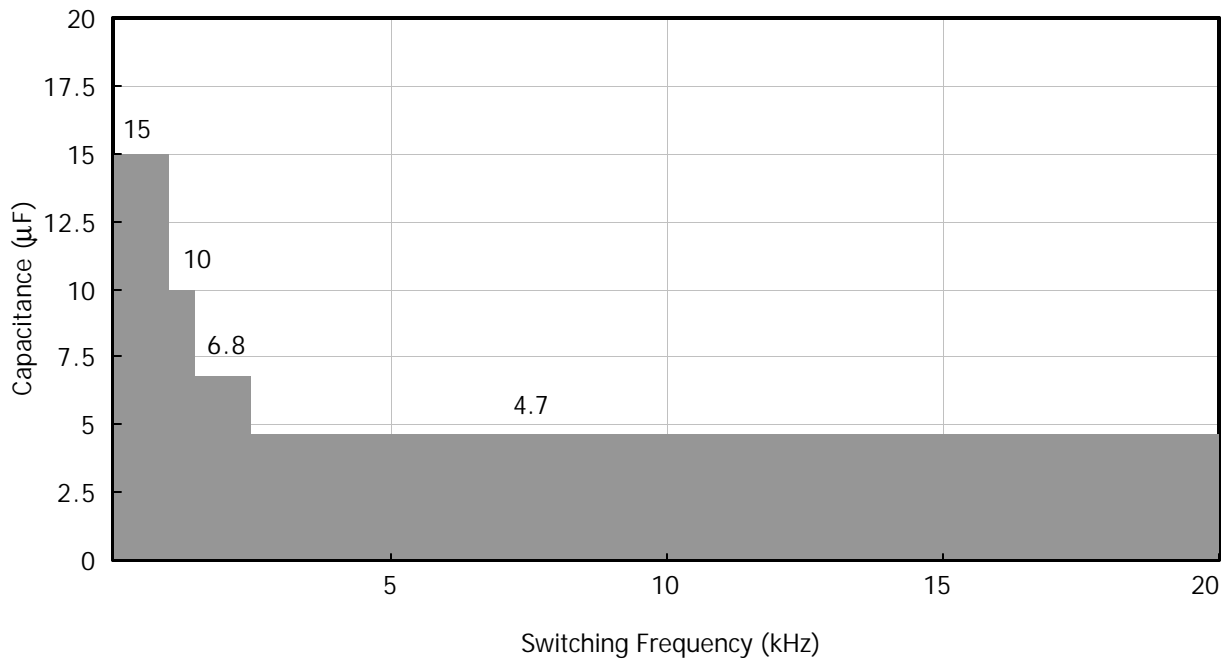

Figure 10. Recommended minimum Bootstrap Capacitor value Vs Switching Frequency

Figure 11. Switching Parameter Definitions

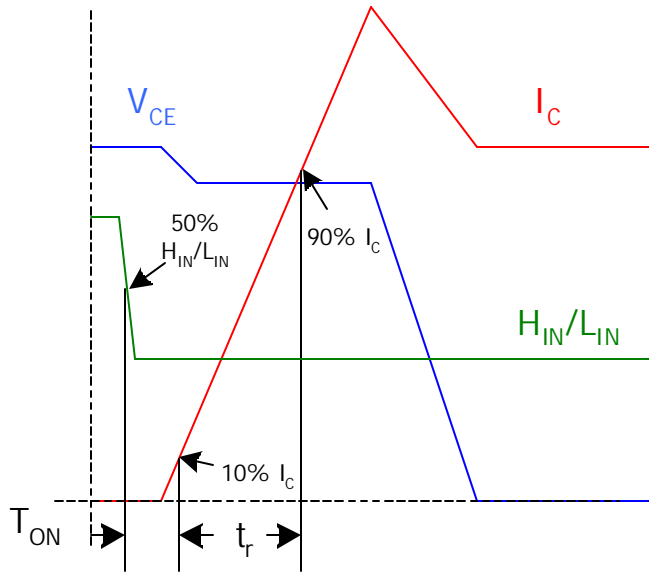

Figure 11a. Input to Output propagation turn-on delay time

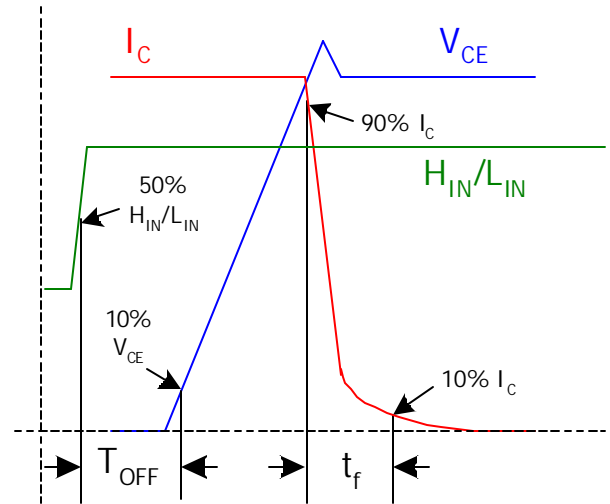

Figure 11b. Input to Output propagation turn-off delay time

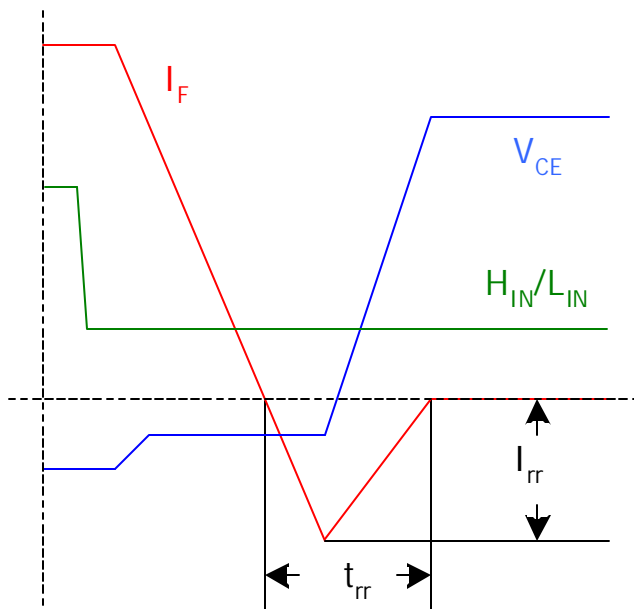

Figure 11c. Diode Reverse Recovery

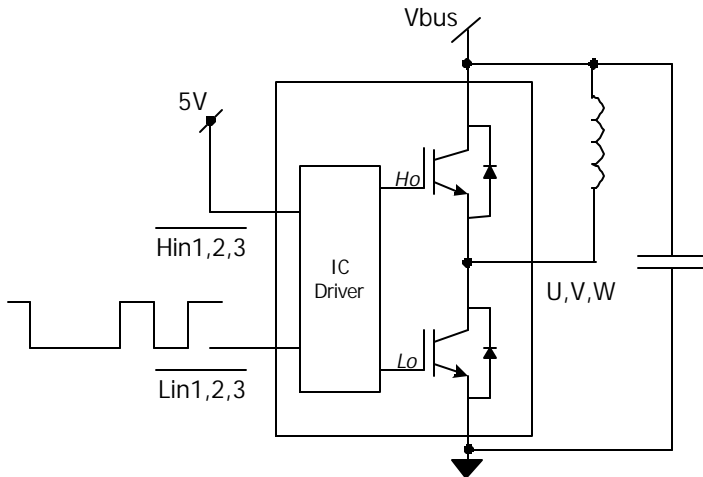

Figure CT1. Switching Loss Circuit

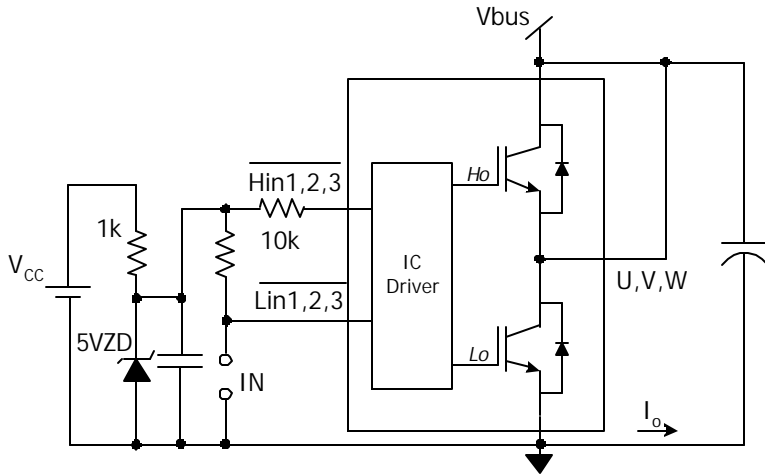

Figure CT2. S.C.SOA Circuit

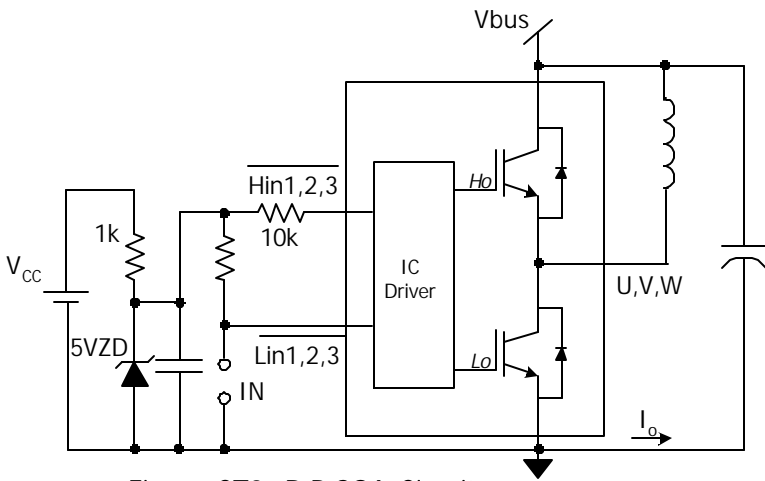
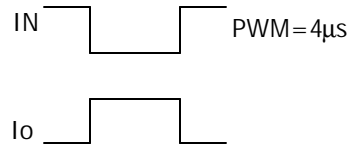
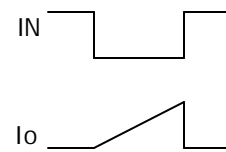
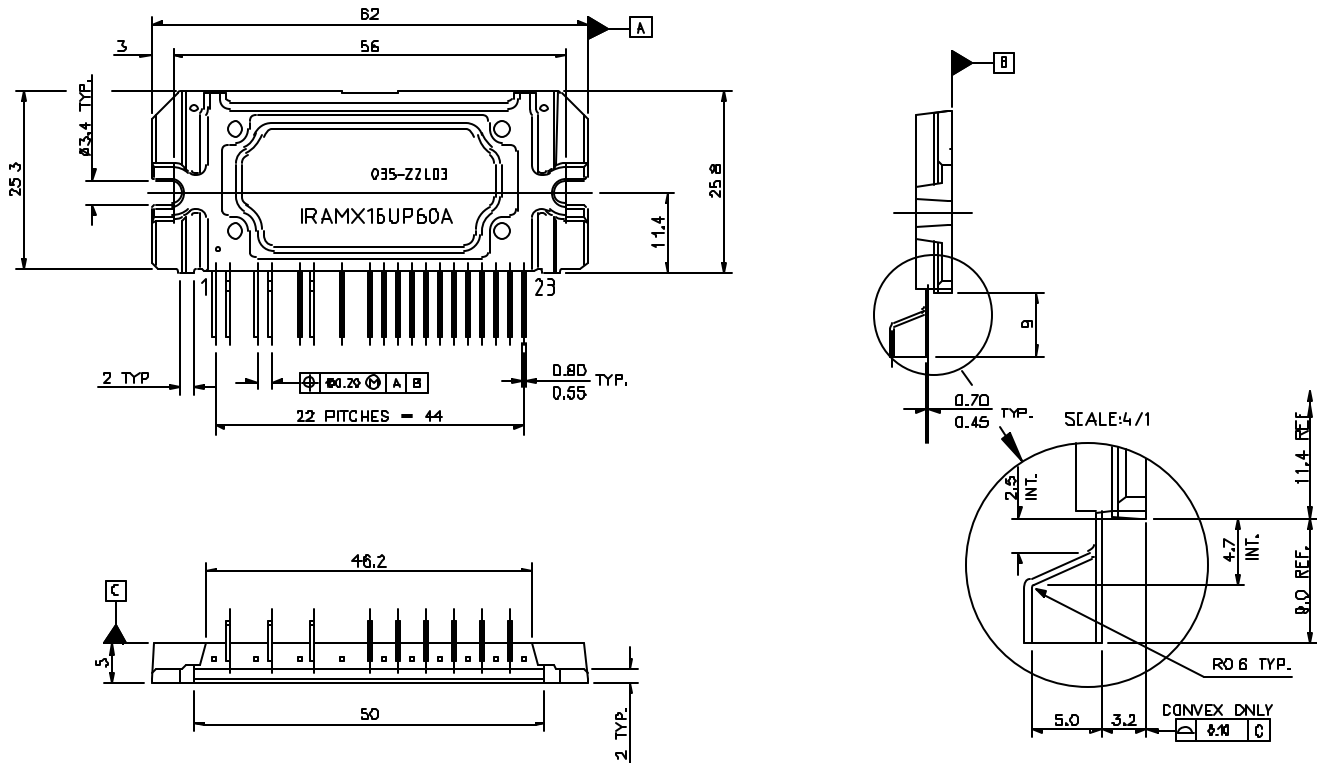

Figure CT3. R.B.SOA Circuit



IRAMX16UP60A

Package Outline



Standard pin leadforming option

Notes:

Dimensions in mm

- 1- Marking for pin 1 identification
- 2- Product Part Number
- 3- Lot and Date code marking

Package Outline

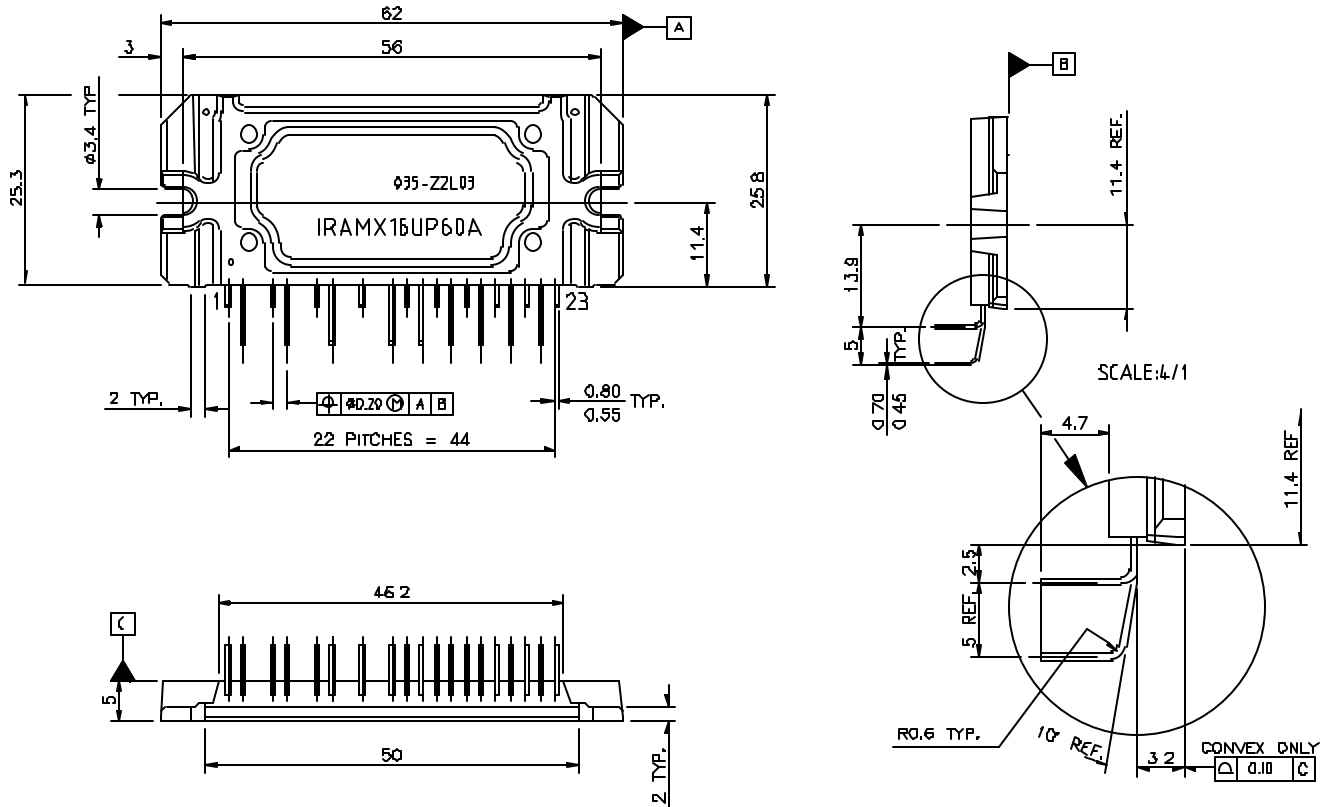

Pin leadforming option -2

Notes:

Dimensions in mm

- 1- Marking for pin 1 identification
- 2- Product Part Number
- 3- Lot and Date code marking