

Electrical Characteristics

(Unless otherwise specified, $V_{in}=V_o(TYP.)+1.0V$, $I_o=30mA$, $V_c=1.8V$, $T_a=25^{\circ}C$)

Parameter	Symbol	Conditions	MIN.	TYP.	MAX.	Unit
Output voltage	V_o	—	Refer to the table below			V
Load regulation	R_{egL}	$I_o=5mA$ to $300mA$	—	35	160	mV
Line regulation	R_{egI}	$V_{IN}=V_o(TYP.)+1V$ to $V_o(TYP.)+6V(MAX. 9V)$ $I_o=10mA, T_j=-25$ to $+75^{\circ}C$	—	3.0	20	mV
Temperature coefficient of output voltage	T_cV_o	—	—	0.05	—	mV/ $^{\circ}C$
*4 Ripple rejection	RR	—	—	70	—	dB
*4 Output noise voltage	$V_{no(rms)}$	$10Hz < f < 100kHz$, $I_o=30mA, C_n=0.1\mu F$	—	30	—	μV
Dropout voltage	V_{I-O}	$I_o=300mA$, *5	—	—	0.7	V
*6 ON-state voltage for control	$V_{c(on)}$	—	1.8	—	—	V
ON-state current for control	$I_{c(on)}$	$V_c=1.8V$	—	5	30	μA
OFF-state voltage for control	$V_{c(off)}$	—	—	—	0.4	V
Quiescent current	I_q	$I_o=0mA$	—	—	500	μA
Output OFF-state dissipation current	I_{qs}	$V_c=0.2V$	—	—	1	μA

*4 Typical value at output voltage is 3.0V type.

*5 Input voltage when output voltage lowers 100mV from the voltage at $V_{in}=V_o(TYP.)+1.0V$.

*6 In case of opening control terminal ③, output voltage turns off.

Output Voltage Line-up

($V_{IN}=V_o(TYP.)+1.0V, I_o=30mA, V_c=1.8V, T_a=25^{\circ}C$)

Parameter	Symbol	Conditions	MIN.	TYP.	MAX.	Unit
*7 Output voltage	V_o	—	1.740	1.8	1.860	V
			2.040	2.1	2.160	
			2.440	2.5	2.560	
			2.940	3.0	3.060	
			3.234	3.3	3.366	
			3.332	3.4	3.468	
			4.900	5.0	5.100	

*7 It is available for every 0.1V (1.3V to 5V)

Fig.1 Test Circuit

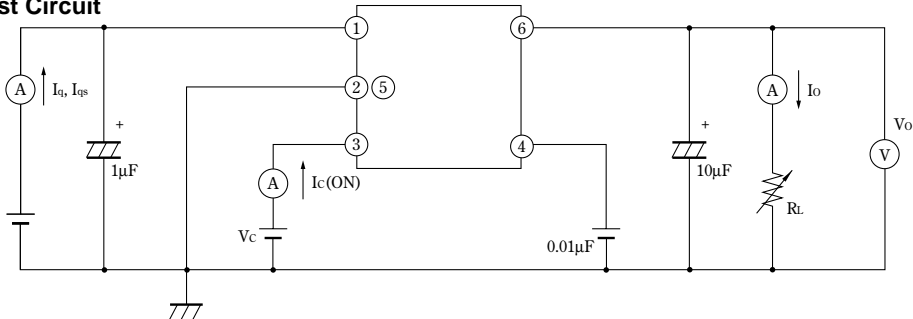

Fig.2 Test Circuit for Ripple Rejection

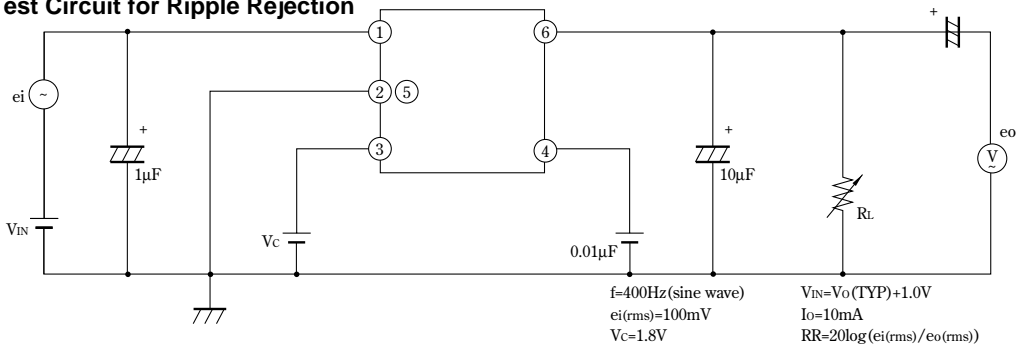
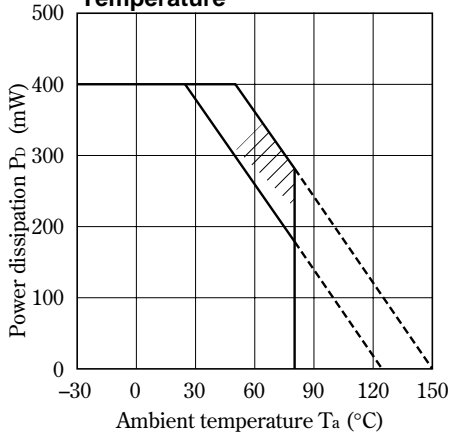

Fig.3 Power Dissipation vs. Ambient Temperature



Note) Oblique line portion: Overheat protection may operate in this area.

Fig.5 Output Voltage Fluctuation vs. Junction Temperature (PQ1K333M2ZP) (Typical Value)

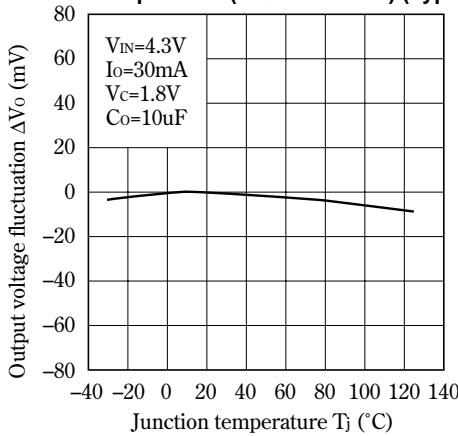

Fig.4 Overcurrent Protection Characteristics (Typical Value)

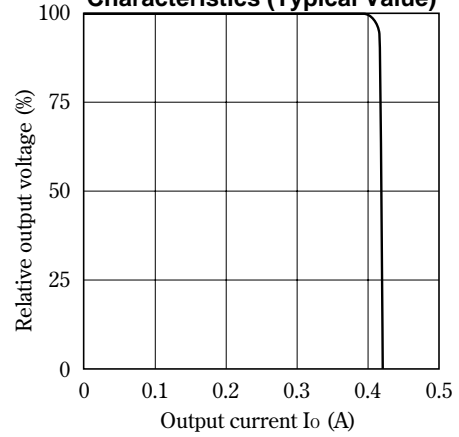

Fig.6 Output Voltage vs. Input Voltage (PQ1K333M2ZP) (Typical Value)

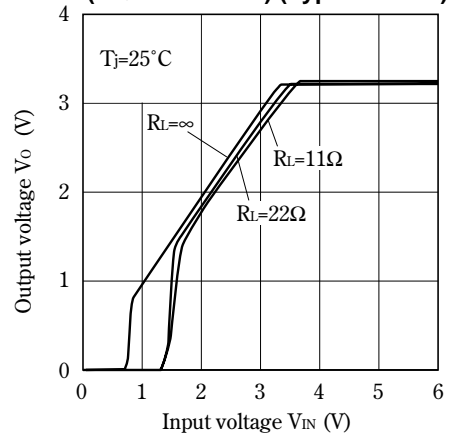

Fig.7 Circuit Operating Current vs. Input Voltage (PQ1K333M2ZP) (Typical Value)

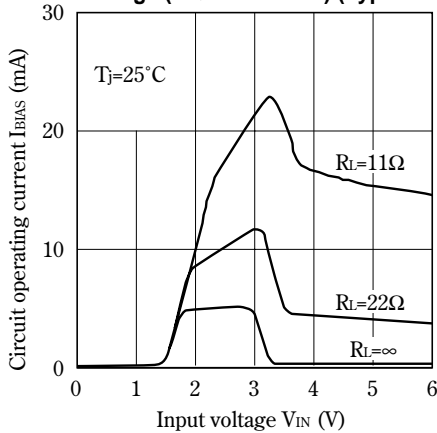

Fig.8 Dropout Voltage vs. Junction Temperature (Typical Value)

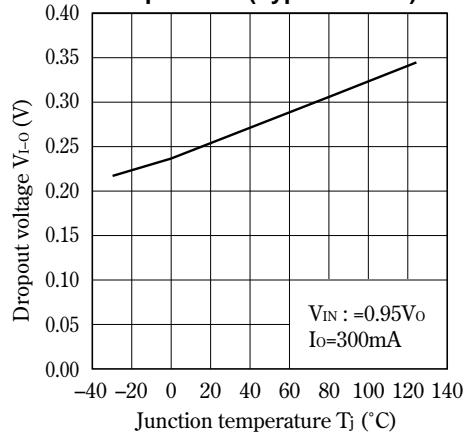

Fig.9 Quiescent Current vs. Junction Temperature

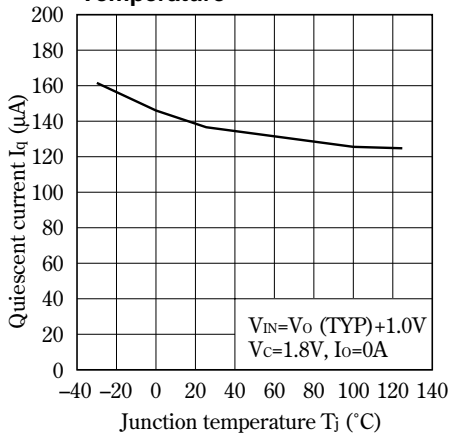

Fig.10 Ripple Rejection vs. Input Ripple Frequency (PQ1K333M2ZP) (Typical Value)

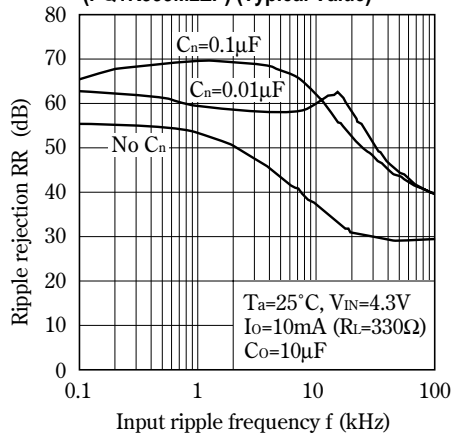

Fig.11 Dropout Voltage vs. Output Current (PQ1K333M2ZP) (Typical Value)

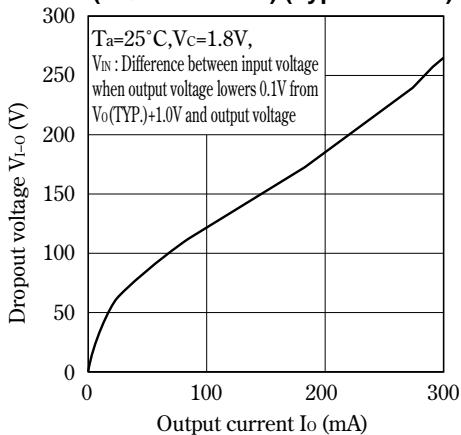
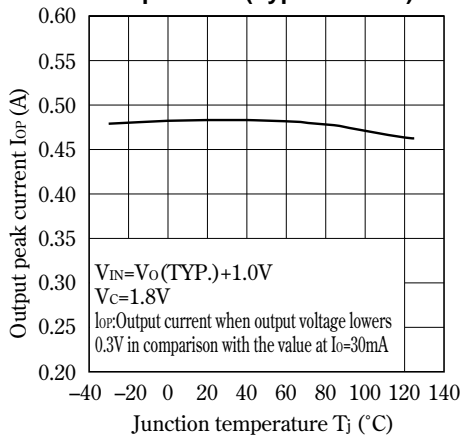
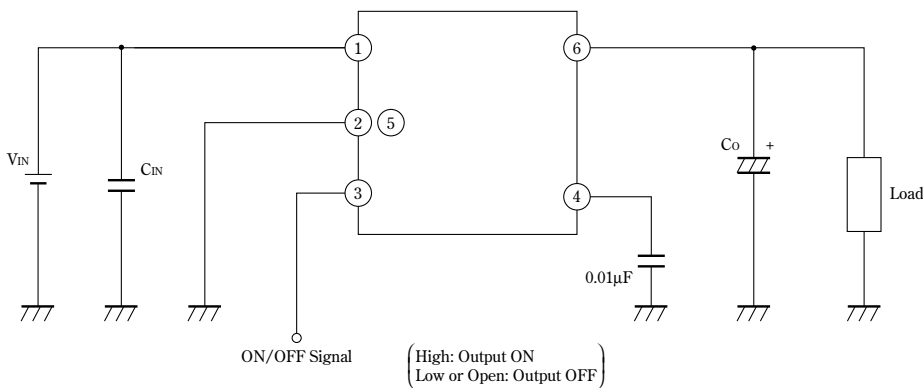

Fig.12 Output Peak Current vs. Junction Temperature (Typical Value)



■ ON/OFF Operation



NOTICE

- The circuit application examples in this publication are provided to explain representative applications of SHARP devices and are not intended to guarantee any circuit design or license any intellectual property rights. SHARP takes no responsibility for any problems related to any intellectual property right of a third party resulting from the use of SHARP's devices.
- Contact SHARP in order to obtain the latest device specification sheets before using any SHARP device. SHARP reserves the right to make changes in the specifications, characteristics, data, materials, structure, and other contents described herein at any time without notice in order to improve design or reliability. Manufacturing locations are also subject to change without notice.
- Observe the following points when using any devices in this publication. SHARP takes no responsibility for damage caused by improper use of the devices which does not meet the conditions and absolute maximum ratings to be used specified in the relevant specification sheet nor meet the following conditions:
 - (i) The devices in this publication are designed for use in general electronic equipment designs such as:
 - Personal computers
 - Office automation equipment
 - Telecommunication equipment [terminal]
 - Test and measurement equipment
 - Industrial control
 - Audio visual equipment
 - Consumer electronics
 - (ii) Measures such as fail-safe function and redundant design should be taken to ensure reliability and safety when SHARP devices are used for or in connection with equipment that requires higher reliability such as:
 - Transportation control and safety equipment (i.e., aircraft, trains, automobiles, etc.)
 - Traffic signals
 - Gas leakage sensor breakers
 - Alarm equipment
 - Various safety devices, etc.
 - (iii) SHARP devices shall not be used for or in connection with equipment that requires an extremely high level of reliability and safety such as:
 - Space applications
 - Telecommunication equipment [trunk lines]
 - Nuclear power control equipment
 - Medical and other life support equipment (e.g., scuba).
- Contact a SHARP representative in advance when intending to use SHARP devices for any "specific" applications other than those recommended by SHARP or when it is unclear which category mentioned above controls the intended use.
- If the SHARP devices listed in this publication fall within the scope of strategic products described in the Foreign Exchange and Foreign Trade Control Law of Japan, it is necessary to obtain approval to export such SHARP devices.
- This publication is the proprietary product of SHARP and is copyrighted, with all rights reserved. Under the copyright laws, no part of this publication may be reproduced or transmitted in any form or by any means, electronic or mechanical, for any purpose, in whole or in part, without the express written permission of SHARP. Express written permission is also required before any use of this publication may be made by a third party.
- Contact and consult with a SHARP representative if there are any questions about the contents of this publication.