



+2.5V Precision Voltage Reference

REF-03

FEATURES

- **+2.5 Volt Output** $\pm 0.6\%$ Max
- **Wide Input Voltage Range** 4.5V to 33V
- **Supply Current** 1.4mA Max
- **Output Voltage Tempco** 50ppm/°C Max
- **Line Regulation** 50ppm/V Max
- **Load Regulation** 100ppm/mA Max
- **Extended Industrial Temp Range** -40°C to +85°C
- **Low Cost**
- **Available in Die Form**

ORDERING INFORMATION†

| PLASTIC PACKAGE | OPERATING TEMPERATURE RANGE |
|-----------------|-----------------------------|
| REF03GP | XIND |
| REF03GS†† | XIND |

† Burn-in is available on commercial and industrial temperature range parts in plastic DIP.
 †† For availability and burn-in information on SO and PLCC packages, contact your local sales office.

GENERAL DESCRIPTION

The REF-03 precision voltage reference provides a stable +2.5V output, with minimal change for variations in supply voltage, ambient temperature or loading conditions. Single-supply operation over an input voltage range of +4.5V to +33V with a current drain of 1mA and good temperature stability is achieved using an improved bandgap design. Primarily targeted at price-sensitive applications, the REF-03 is available in plastic minidips and surface-mountable small outline plastic packages. For improved performance or -55°C/125°C operation, see the REF-43 data sheet.

PIN CONNECTIONS

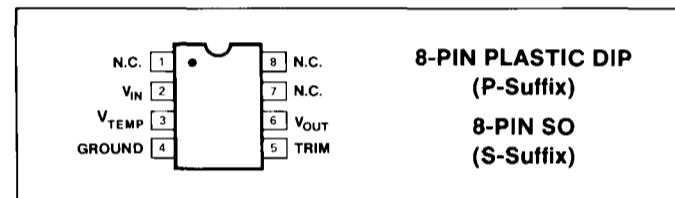

SIMPLIFIED SCHEMATIC

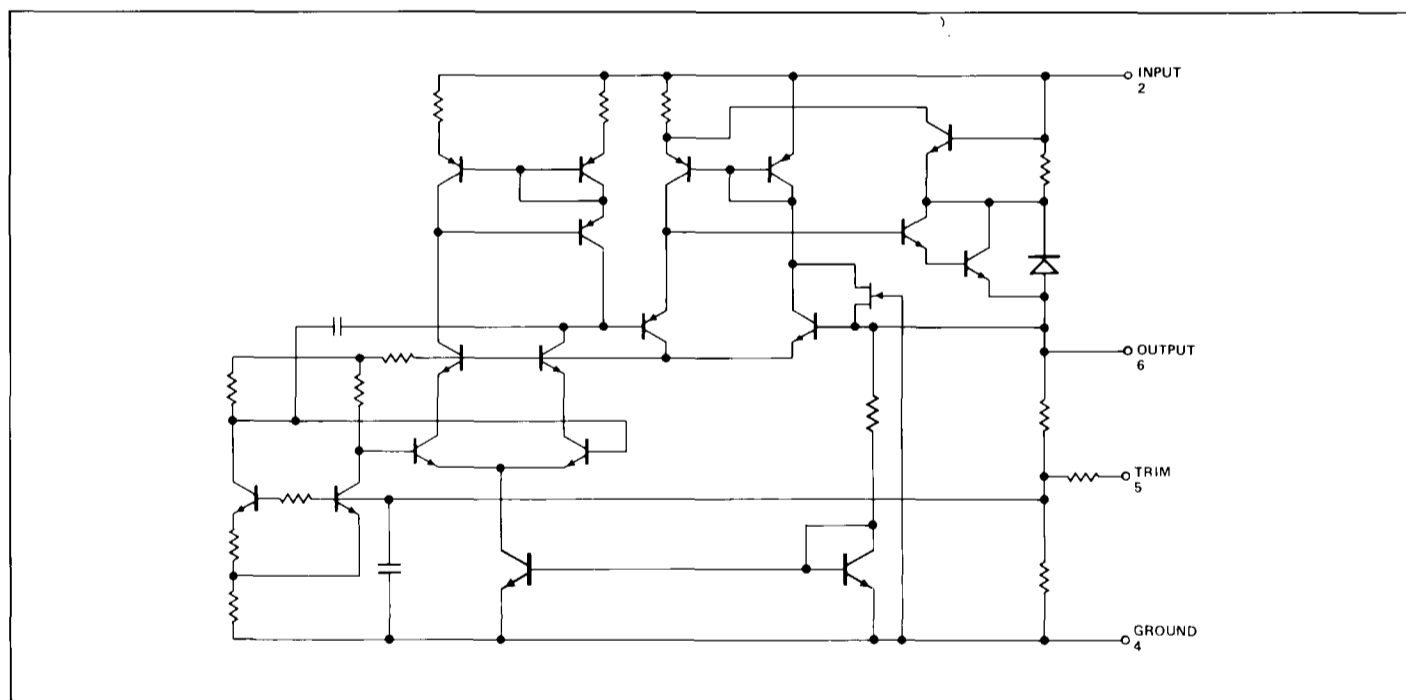

REV. C

Information furnished by Analog Devices is believed to be accurate and reliable. However, no responsibility is assumed by Analog Devices for its use, nor for any infringements of patents or other rights of third parties which may result from its use. No license is granted by implication or otherwise under any patent or patent rights of Analog Devices.

One Technology Way, P.O. Box 9106, Norwood, MA 02062-9106, U.S.A.
 Tel: 617/329-4700 Fax: 617/326-8703 Twx: 710/394-6577
 Telex: 924491 Cable: ANALOG NORWOODMASS

REF-03

ABSOLUTE MAXIMUM RATINGS (Note 1)

| | |
|--|-----------------|
| Supply Voltage | +40V |
| Output Short-Circuit Duration | Indefinite |
| Operating Temperature Range | |
| REF-03G (P,S) | -40°C to +85°C |
| Storage Temperature Range | -65°C to +175°C |
| Junction Temperature Range | -65°C to +175°C |
| Lead Temperature (Soldering, 10 sec) | +300°C |

| PACKAGE TYPE | θ_{JA} (NOTE 2) | θ_{JC} | UNITS |
|-----------------------|------------------------|---------------|-------|
| 8-Pin Plastic DIP (P) | 110 | 50 | °C/W |
| 8-Pin SO (S) | 160 | 44 | °C/W |

NOTES:

1. Absolute maximum ratings apply to both DICE and packaged parts, unless otherwise noted.
2. θ_{JA} is specified for worst case mounting conditions, i.e., θ_{JA} is specified for device in socket for P-DIP package; θ_{JA} is specified for device soldered to printed circuit board for SO package.

ELECTRICAL CHARACTERISTICS at $V_{IN} = +15V$, $-40^\circ C \leq T_A \leq +85^\circ C$, unless otherwise noted.

| PARAMETER | SYMBOL | CONDITIONS | REF-03G | | | UNITS |
|--|-------------------|-------------------------------|---------|----------|-------|---------------|
| | | | MIN | TYP | MAX | |
| Output Voltage | V_O | No Load | 2.485 | 2.500 | 2.515 | V |
| Output Voltage Tolerance | | No Load | — | 0.2 | 0.6 | % |
| Output Voltage Temperature Coefficient | TCV_O | (Note 1) | — | 10 | 50 | ppm/°C |
| Line Regulation | | $V_{IN} = +4.5V$ to $+33V$ | — | 20 | 50 | ppm/V |
| | | | — | 0.002 | 0.005 | %/V |
| Load Regulation | | $I_L = 0mA$ to $10mA$ | — | 60 | 100 | ppm/mA |
| | | | — | 0.006 | 0.010 | %/mA |
| Load Current (Sourcing) | I_L | | 10 | 21 | — | mA |
| Load Current (Sinking) | I_S | | -0.3 | -0.5 | — | mA |
| Short-Circuit Output Current | I_{SC} | Output Shorted to Ground | — | 24 | — | mA |
| Quiescent Supply Current | I_{SY} | No Load | — | 1.0 | 1.4 | mA |
| Turn-On Settling Time | t_{ON} | To $\pm 0.1\%$ of Final Value | — | 5 | — | μs |
| Output Voltage Noise | e_{np-p} | 0.1Hz to 10Hz | — | 6 | — | μV_{p-p} |
| Output Adjustment Range | ΔV_{TRIM} | $R_{POT} = 10k\Omega$ | ± 6 | ± 11 | — | % |
| Input Voltage Range | | | 4.5 | 15 | 33 | V |
| Temperature Voltage Output | V_T | (Note 2) | — | 620 | — | mV |

NOTES:

1. TCV_O is measured by the endpoint method, and is equal to $\left| \frac{V(85^\circ C) - V(-40^\circ C)}{(2.5 \times 10^{-6})(125^\circ C)} \right|$ in ppm/°C.

2. Limit current in or out of pin 3 to 50nA and capacitance on pin 3 to 30pF.

BURN-IN CIRCUIT

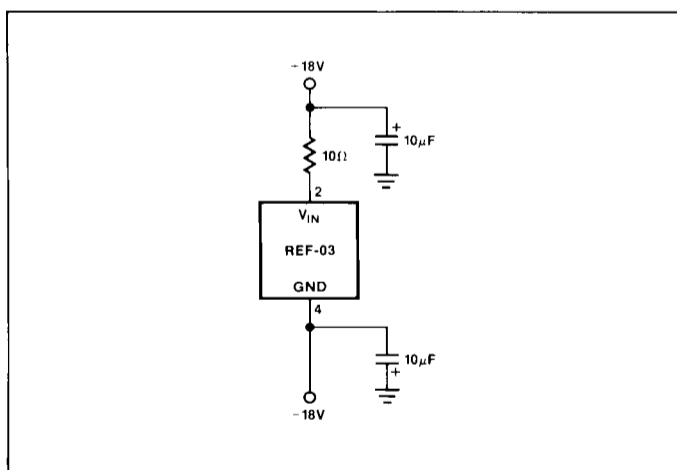

OUTPUT VOLTAGE TRIM METHOD

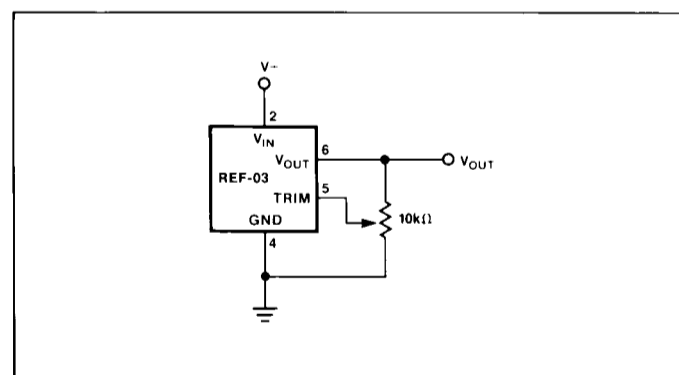

DICE CHARACTERISTICS

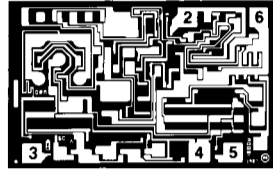

2. V_{IN}
3. V_{TEMP}
4. GROUND
5. TRIM
6. V_{OUT}

DIE SIZE 0.048 × 0.074 inch, 3552 sq. mils
(1.22 × 1.88 mm, 2.29 sq. mm)

WAFER TEST LIMITS at $V_{IN} = +15V$, $T_A = 25^\circ C$.

| PARAMETER | SYMBOL | CONDITIONS | REF-03G LIMIT | UNITS |
|--------------------------|------------|--------------------------|------------------|-----------|
| Output Voltage Tolerance | V_O | $I_L = 0$ | 2.500 ± 0.015 | V MAX |
| | | | 0.6 | % MAX |
| Line Regulation | | $V_{IN} = +4.5V$ to +33V | 50 | ppm/V MAX |
| | | | 0.005 | % MAX |
| Output Adjust Range | V_{TRIM} | $R_p = 10k\Omega$ | ± 6 | % MIN |
| Quiescent Supply Current | I_{SY} | No Load | 1.4 | mA MAX |

NOTE:

Electrical tests are performed at wafer probe to the limits shown. Due to variations in assembly methods and normal yield loss, yield after packaging is not guaranteed for standard product dice. Consult factory to negotiate specifications based on dice lot qualification through sample lot assembly and testing.

TYPICAL PERFORMANCE CHARACTERISTICS

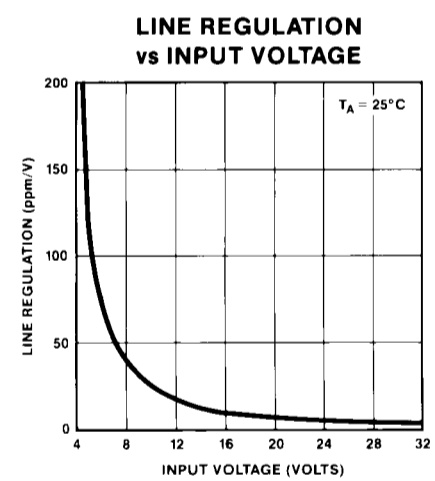
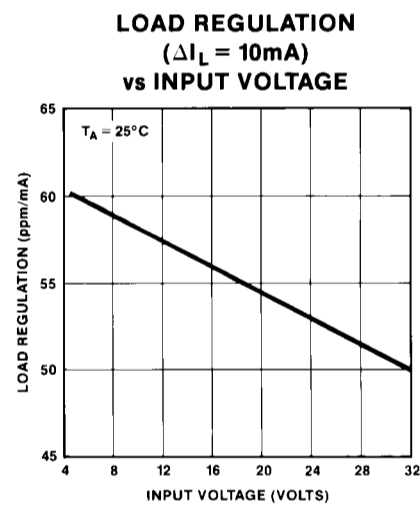
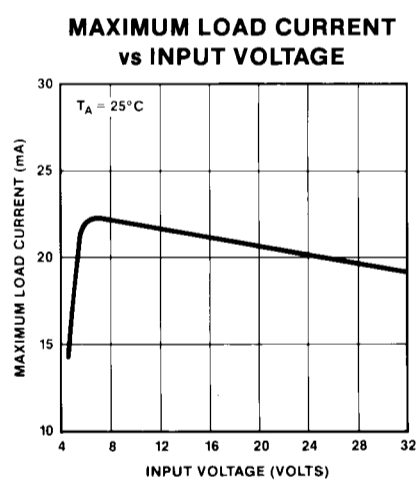

REF-03

TYPICAL PERFORMANCE CHARACTERISTICS

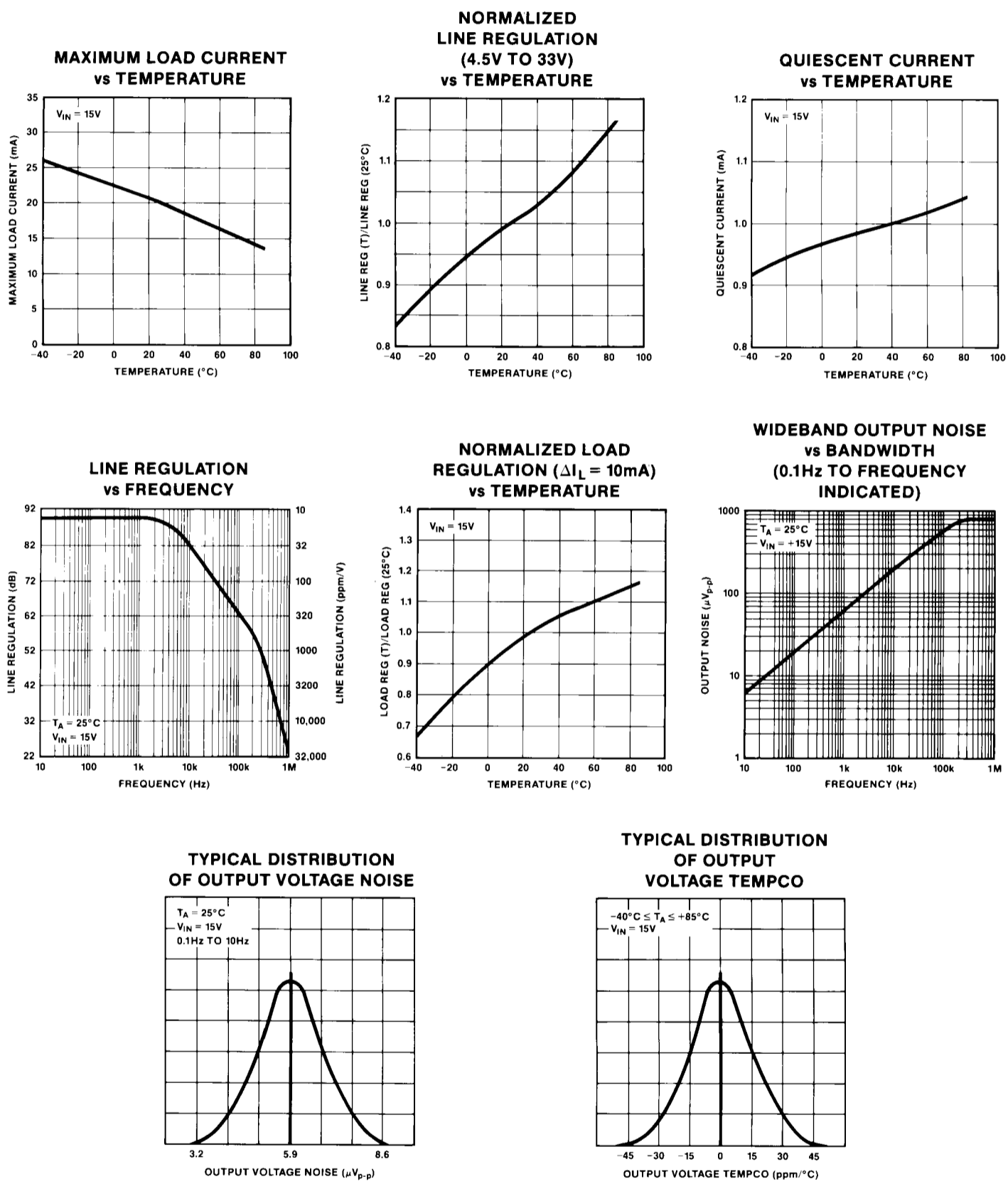

APPLICATIONS INFORMATION

The REF-03 provides a stable +2.5V output voltage with minimal dependence on load current, line voltage or temperature. This voltage is typically used to set an absolute reference point in data conversion circuits, or in analog circuits such as log amps, 4-20mA transmitters and power supplies. The REF-03 is of particular value in systems requiring a precision reference using a single +5V supply rail.

Because an onboard operational amplifier is used to amplify the basic bandgap cell voltage to 2.5V, supply decoupling is critical to the transient performance of a voltage reference. The supply line should be bypassed with a 10 μ F tantalum capacitor in parallel with a 0.01 μ F to 0.1 μ F ceramic capacitor for best results as shown in Figure 1. For less critical conditions, a single 0.1 μ F capacitor is adequate. The bypass capacitors should be located as close to the reference as possible. Inadequate bypassing can lead to instabilities.

Output bypass capacitors are not generally recommended. If necessary for high-frequency output impedance reduction, the capacitance value used should be at least 1 μ F.

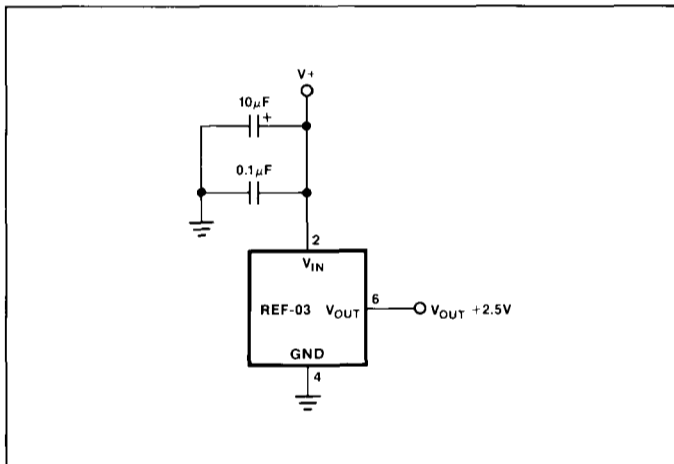
FIGURE 1: Basic Connections**GENERATING AN ADJUSTABLE BIPOLAR VOLTAGE REFERENCE**

Many times, there is a requirement for an adjustable bipolar reference. A simple method of generating such a reference is to connect the output of the REF-03 to an op amp in an adjustable gain configuration as shown in Figure 2. The trimable resistor is then used to generate the desired output voltage from -2.5V to +2.5V.

GENERATING A -2.5V REFERENCE

Often, there is a requirement for a negative reference voltage. The simplest method of generating a -2.5V reference with the REF-03 is to connect an op amp in a gain of -1 to the output, as shown in Figure 3. This provides both positive and negative 2.5V references. Figure 4 shows another method of obtaining a negative reference, in which the current-output element is a PNP transistor, with the REF-03 in a servo loop to ensure that the output remains 2.5V below ground.

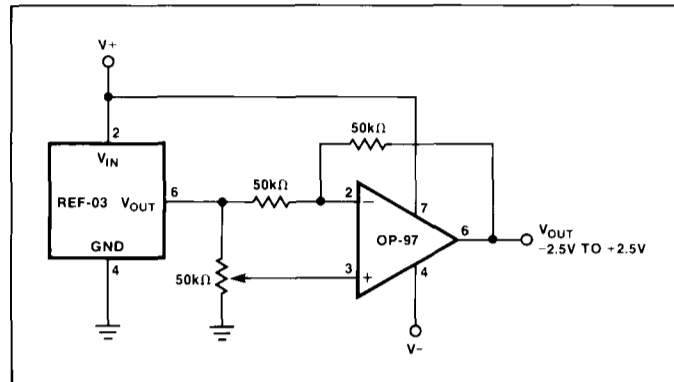
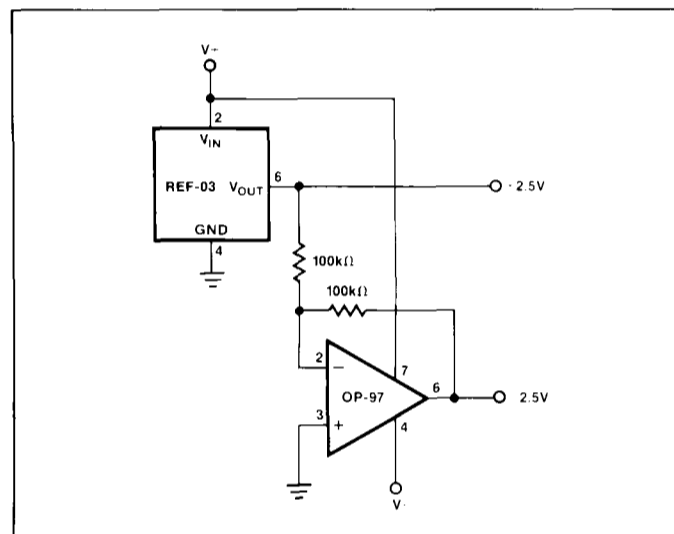
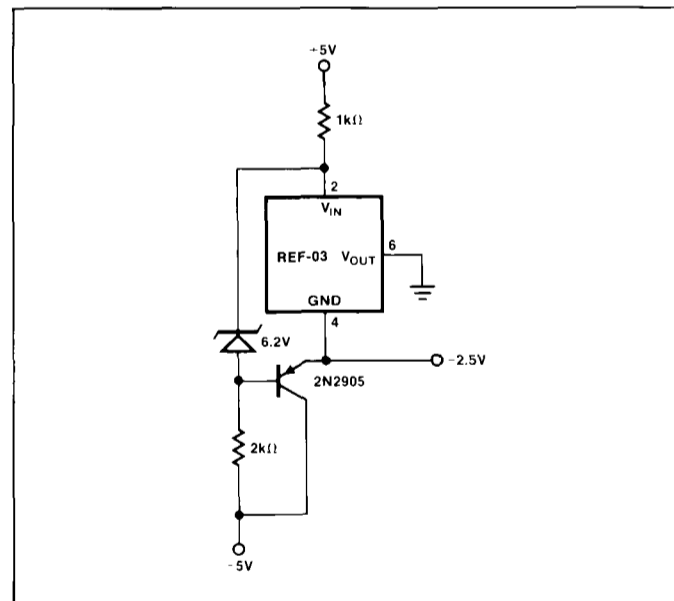
FIGURE 2: Adjustable Bipolar Reference**FIGURE 3: ±2.5V Reference****FIGURE 4: -2.5V Reference**

REF-03

BOOST TRANSISTOR PROVIDES HIGH OUTPUT CURRENT

When applications require more than 10mA current delivery, an external boost transistor may be added to the REF-03 to pass the required current without dissipating excessive power within the IC. The maximum current output to the system is bounded only by the capabilities of the boost transistor. This technique is shown in Figure 5 with and without current limiting. Current limiting may be used to prevent damage to the boost transistor. In Figure 5b, the limit occurs when the voltage dropped across R2 exceeds one V_{BE} (0.6V). The current limit is sensitive to the variations of the diodes' forward drop and the PNP's V_{BE} with temperature, and will decrease with increasing temperature.

CMOS DAC REFERENCE

The REF-03 makes an excellent reference for use with CMOS and bipolar DACs. Figure 6 shows the REF-03 connected to the DAC-8012, a 12-bit parallel loading CMOS DAC with memory. With an OP-43 output amplifier for fast settling, the circuit requires less than 3mA when driven from TTL gates, and less than 2mA when driven from CMOS gates. In situations not requiring the higher speed of the OP-43, enhanced linearity and some savings in power dissipation can be realized using an OP-97 for the output amplifier. Figure 7 shows a typical multiplying DAC application using a REF-03 reference.

FIGURE 5: Output Current Boost

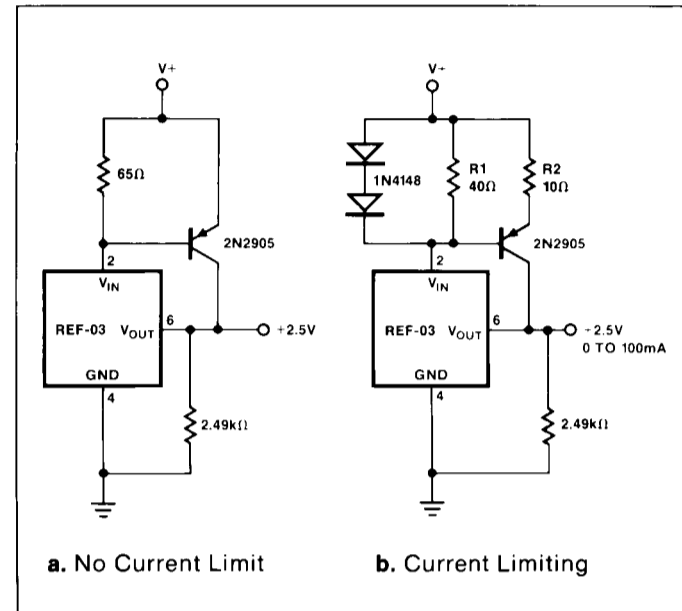

FIGURE 6: CMOS DAC Reference

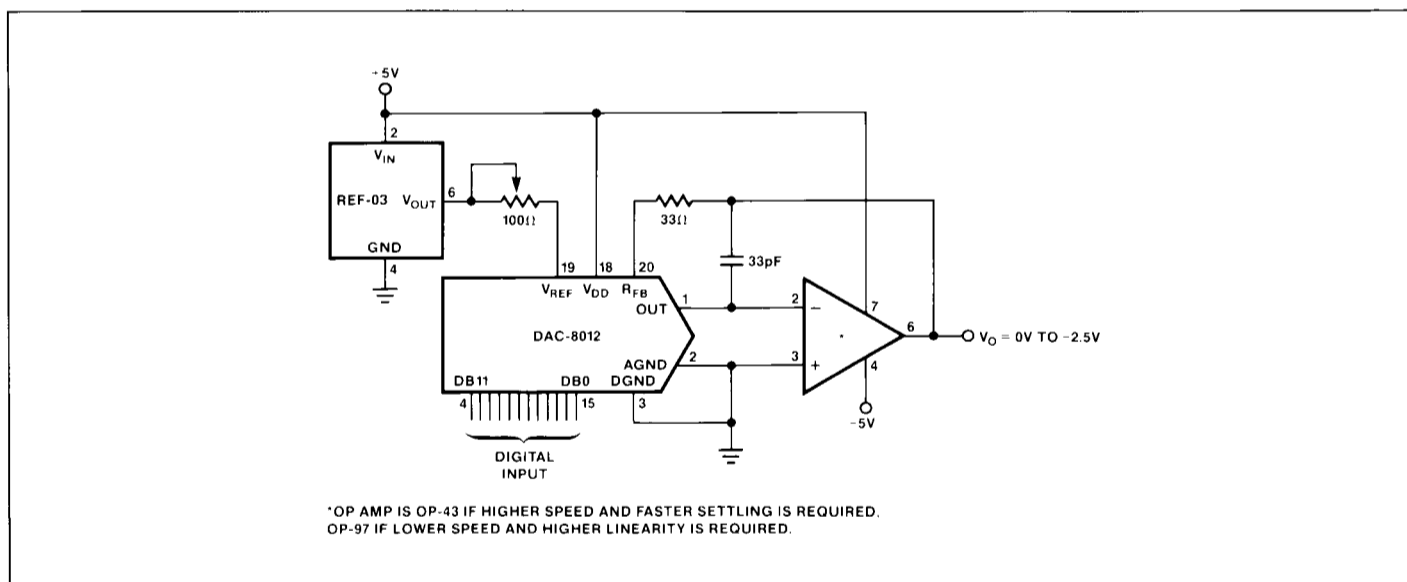

FIGURE 7: Multiplying CMOS DAC Reference

