

## VARIABLE Q FILTER

### DESCRIPTION

The ZXF103 is a versatile analog high Q bandpass filter. It can be configured to provide pass or notch characteristics.

The basic filter section requires 2 resistors and 2 capacitors to set the centre frequency. The frequency range is up to 600kHz. Two external resistors control filter Q Factor. The Q can be varied up to 50.

### APPLICATIONS

Many filter applications including: -

- Sonar and Ultrasonic Systems
- Line frequency notch
- Signalling
- Motion detection
- Instrumentation
- Low frequency telemetry

### ORDERING INFORMATION

PART NUMBER	PACKAGE	PART MARK
ZXF103Q16	QSOP16	ZXF103
PART NUMBER	CONTAINER	INCREMENT
ZXF103Q16TA	Reel 7" 178mm	500
ZXF103Q16TC	Reel 13" 330mm	2500

### FEATURES AND BENEFITS

- Centre Frequency up to 1MHz
- Variable Q up to 50
- Low distortion
- Low noise
- Low power 25mW
- Devices easily cascaded
- Small QSOP16 package

### SYSTEM DIAGRAM

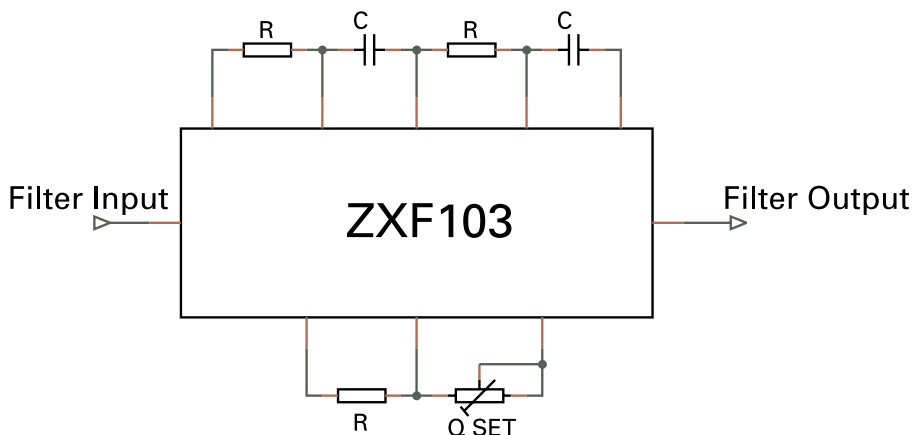

# ZXF103

## ABSOLUTE MAXIMUM RATINGS

Voltage on any pin	7.0V (relative to 0V)
Operating temperature range	0 to 70°C
Storage temperature	-55 to 125°C

## ELECTRICAL CHARACTERISTICS

Test Conditions: Temperature =25°C, V<sub>cc</sub> = 5.00V, 0V = 0.00V, R<sub>L</sub>=10k, C<sub>L</sub>=10pF

GENERAL CHARACTERISTICS					
Parameter	Conditions	Min.	Typical	Max.	Units
Operating current			4.0	5.0	mA
Max. operating frequency	V <sub>out</sub> =1.6V p-p V <sub>out</sub> =1.0V p-p			600 1000	kHz
Q usable range		0.5		50	
Centre Frequency temperature coefficient	Q=30, fo = 1kHz		100		ppm/°C
Q temperature coefficient	Q=30, fo = 1kHz		0.1		% /°C
Voltage noise	1 – 100 kHz		20		nV/√Hz
Input impedance		10	15	20	kΩ
Linear Output Range	Output load =10 kΩ		2		V pk-pk
Sink current			450		μA
Source current			450		μA
Output impedance			10		Ω

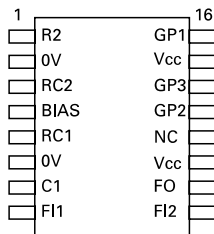

Pin	Name	Function
1	R2	Phase retard node
2	0V	0 Volts
3	RC2	Phase retard node
4	BIAS	Internal bias generator
5	RC1	Phase advance node
6	0V	0 Volts
7	C1	Phase advance node
8	FI1	Filter input mode dependent
9	FI2	Filter input, mode dependent
10	FO	Filter output for all modes
11	Vcc	+5 Volt supply
12	N/C	No connection
13	GP2	Loop gain node
14	GP3	Loop gain node
15	Vcc	+5 Volt supply
16	GP1	Loop gain node

## Filter Configurations and Responses Notch Filter

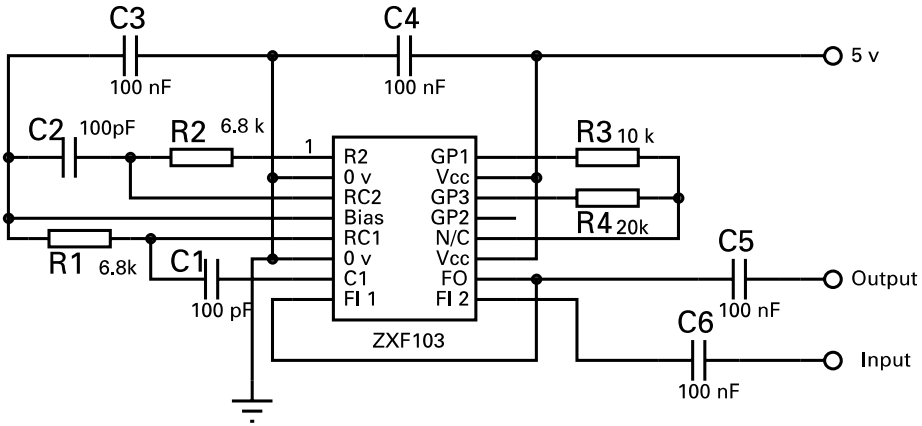

### AC Filter Performance

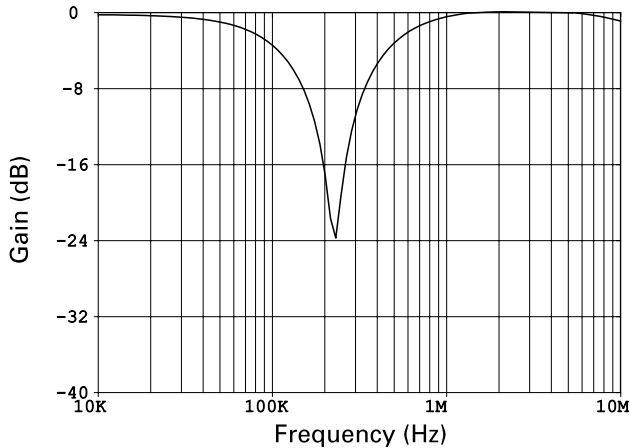

$$F_o = \frac{1}{2\pi RC}$$

where  $R=R_1=R_2$   
and  $C=C_1=C_2$

$$Q \propto \frac{R_4}{R_3}$$

where  $R_1, R_2, R_3$  and  $R_4 \geq 2k\Omega$   
and  $C_1$  and  $C_2 \geq 50pF$

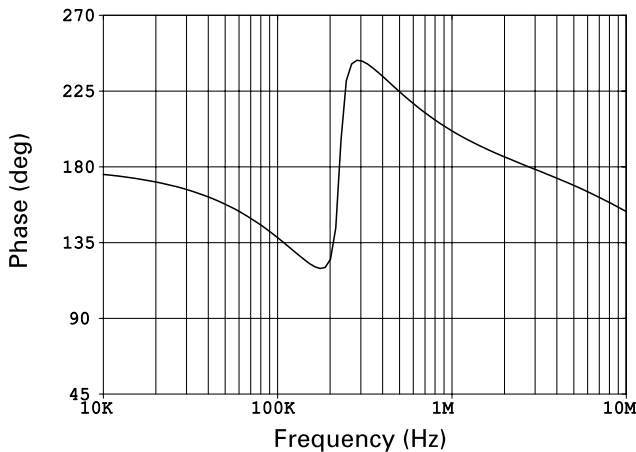

See "Designing for a value of Q"  
for more details.

# ZXF103

## Filter Configurations and Responses (Continued) Inverse Notch Filter (with 0dB Stop Band)

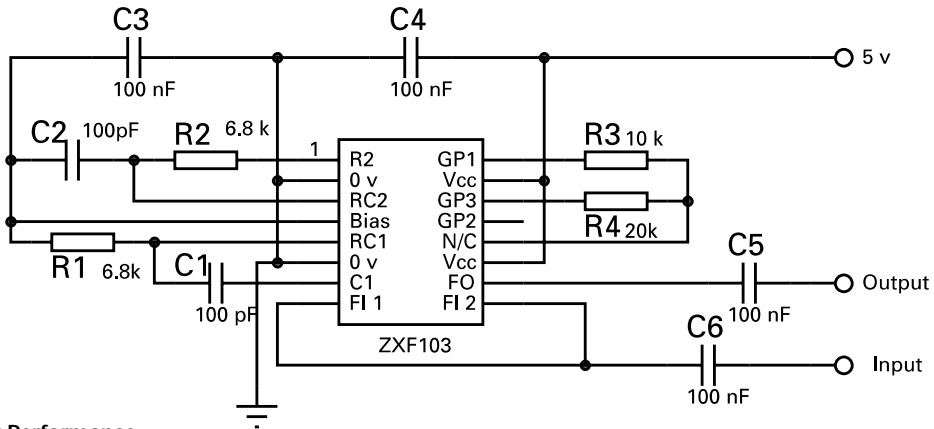

### AC Filter Performance

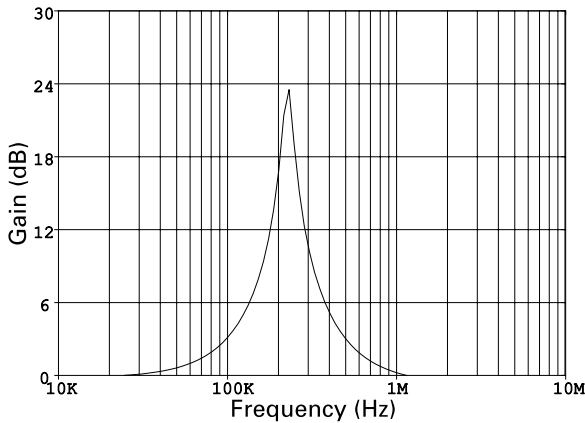

$$F_o = \frac{1}{2\pi RC}$$

where  $R=R_1=R_2$   
and  $C=C_1=C_2$

$$Q \propto \frac{R_4}{R_3}$$

where  $R_1, R_2, R_3$  and  $R_4 \geq 2k\Omega$   
and  $C_1$  and  $C_2 \geq 50pF$



## Filter Configurations and Responses (Continued) Inverse Notch Filter (with attenuating skirts)

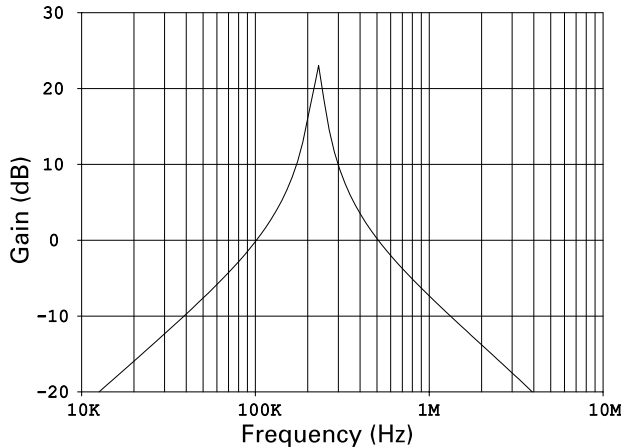
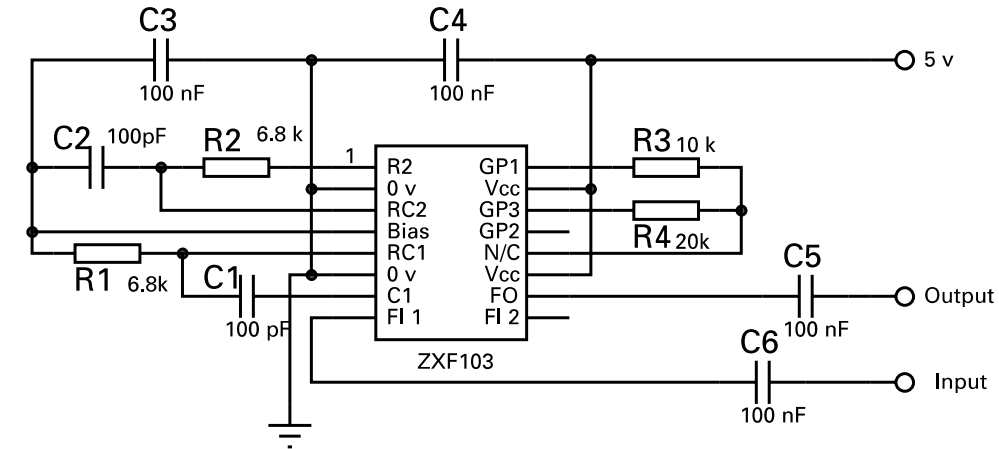

$$F_o = \frac{1}{2\pi RC}$$

where  $R=R_1=R_2$   
and  $C=C_1=C_2$

$$Q \propto \frac{R_4}{R_3}$$

where  $R_1, R_2, R_3$  and  $R_4 \geq 2k\Omega$   
and  $C_1$  and  $C_2 \geq 50pF$

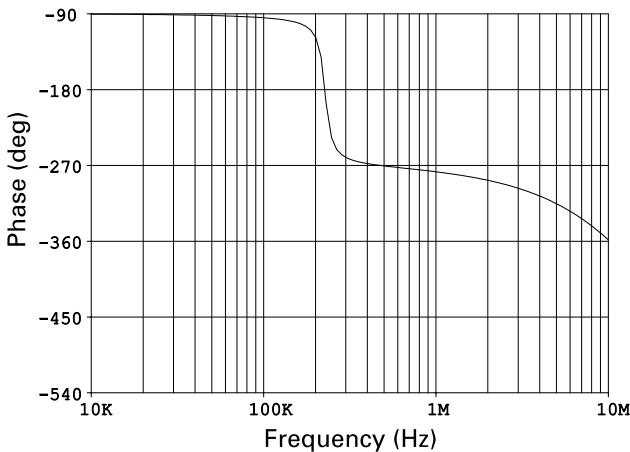

See "Designing for a value of Q" for more details.

The skirt 'roll off' away from the peak is -20dB/Decade regardless of chosen Q.

Typical responses from the circuit with component values derived from the diagram.

# ZXF103

## Designing for a value of Q

As mentioned on the configuration pages, there is a proportional relationship between the ratio of R4 and R3, and Q.

$$Q \propto \frac{R4}{R3}$$

These resistors define the gain of an inverting amplifier that determines the peak value of gain and therefore the Q of the filter, as Q is described as;

$$Q = \frac{Fo}{-3dB\text{Bandwidth}}$$

This value of required gain is quite critical. As the maximum value of Q is approached, too much gain will cause the filter to oscillate at the centre frequency Fo. A small reduction of gain will cause the value of Q to fall significantly. Therefore, for high values of Q factor or tight tolerances of lower values of Q, the resistor ratio must be trimmed.

Frequency dependant effects must be accounted for in determining the appropriate gain. As the frequency increases, the effective circuit gain reduces. The required gain is nominally two but at higher frequencies it will need to be slightly greater than two in order to compensate for loss of gain and internal phase shifts.

This is not really a problem for circuits where the desired Fo remains constant, as the phase shifts are accounted for permanently. For designs where Q is high and Fo is to be 'swept', care must be taken that a gain appropriate at the highest frequency does not cause oscillation at the lowest.

Variation in Q increases from device to device, as the value of Q increases, due to internal gain spreads.

## Evaluation Board Schematic

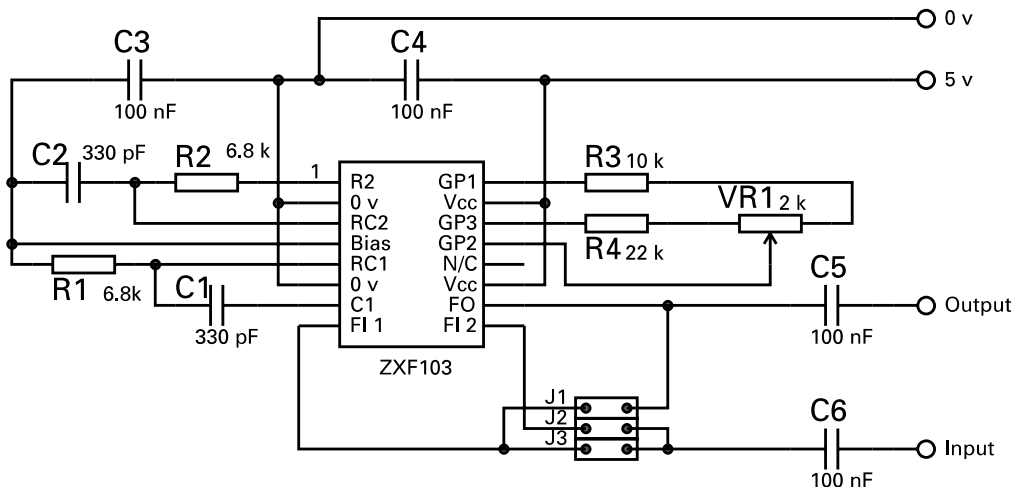

The evaluation board is designed for operation at 70kHz.

Notch	J1 and J2
Notch Pass 1	J2 and J3 (0dB Stop Band)
Notch Pass 2	J3 only (Attenuating skirts)



# ZXF103

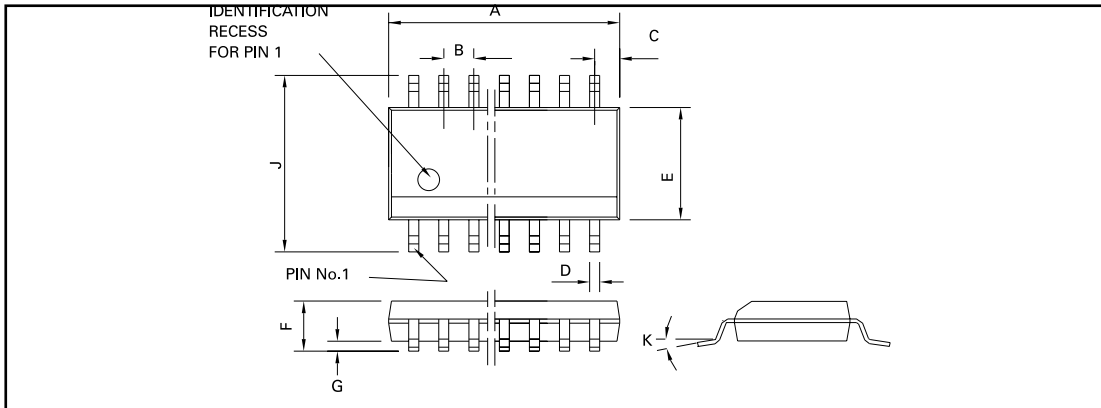

## QSOP16

DIM	Millimetres		Inches	
	MIN	MAX	MIN	MAX
A	4.80	4.98	0.189	0.196
B	0.635		0.025 NOM	
C	0.23 REF		0.009 REF	
D	0.20	0.30	0.008	0.012
E	3.81	3.99	0.15	0.157
F	1.35	1.75	0.053	0.069
G	0.10	0.25	0.004	0.01
J	5.79	6.20	0.228	0.244
K	0°	8°	0°	8°

Conforms to JEDEC MO-137AB Iss A

**ZETEX** Zetex plc.  
 Fields New Road, Chadderton, Oldham, OL9-8NP, United Kingdom.  
 Telephone: (44)161 622 4422 (Sales), (44)161 622 4444 (General Enquiries)  
 Fax: (44)161 622 4420

Zetex GmbH  
 Streifeldstraße 19  
 D-81673 München  
 Germany  
 Telefon: (49) 89 45 49 49 0  
 Fax: (49) 89 45 49 49 49

Zetex Inc.  
 47 Mall Drive, Unit 4  
 Commack NY 11725  
 USA  
 Telephone: (631) 543-7100  
 Fax: (631) 864-7630

Zetex (Asia) Ltd.  
 3701-04 Metroplaza, Tower 1  
 Hing Fong Road,  
 Kwai Fong, Hong Kong  
 Telephone: (852) 26100 611  
 Fax: (852) 24250 494

These are supported by  
 agents and distributors in  
 major countries world-wide  
 © Zetex plc 2001  
[www.zetex.com](http://www.zetex.com)

This publication is issued to provide outline information only which (unless agreed by the Company in writing) may not be used, applied or reproduced for any purpose or form part of any order or contract or be regarded as a representation relating to the products or services concerned. The Company reserves the right to alter without notice the specification, design, price or conditions of supply of any product or service.