

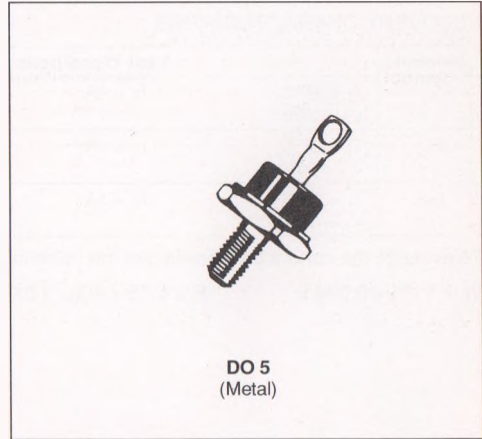

FAST RECOVERY RECTIFIER DIODES

- VERY FAST RECOVERY TIME
- VERY LOW FORWARD RECOVERY TIME
- VERY LOW RECOVERED CHARGE



APPLICATIONS

- DC AND AC MOTOR CONTROL
- SWITCHMODE POWER SUPPLY
- HIGH FREQUENCY CHOPPERS

ABSOLUTE RATINGS (limiting values)

Symbol	Parameter		Value	Unit
I_{FRM}	Repetitive Peak Forward Current	$t_p \leq 20\mu s$	250	A
$I_{F(AV)}$	Average Forward Current	$T_C = 100^\circ C$	30	A
I_{FSM}	Surge non Repetitive Forward Current	$t_p = 10ms$ Sinusoidal	300	A
P_{tot}	Power Dissipation	$T_C = 100^\circ C$	50	W
T_{stg} T_j	Storage and Junction Temperature Range		- 65 to 150	$^\circ C$

Symbol	Parameter	BYX 65-					Unit
		50	100	200	300	400	
V_{RRM}	Repetitive Peak Reverse Voltage	50	100	200	300	400	V

THERMAL RESISTANCE

Symbol	Parameter	Value	Unit
$R_{th(j-c)}$	Junction-case	1	$^\circ C/W$

ELECTRICAL CHARACTERISTICS

STATIC CHARACTERISTICS

Symbol	Test Conditions		Min.	Typ.	Max.	Unit
I_R	$T_j = 100^\circ\text{C}$	$V_R = V_{RRM}$			10	mA
V_F	$T_j = 25^\circ\text{C}$	$I_F = 30\text{A}$			1.5	V

RECOVERY CHARACTERISTICS

Symbol	Test Conditions			Min.	Typ.	Max.	Unit
t_{rr}	$T_j = 25^\circ\text{C}$ $V_R = 30\text{V}$	$I_F = 1\text{A}$	$di_F/dt = -15\text{A}/\mu\text{s}$			100	ns
Q_{rr}	$T_j = 25^\circ\text{C}$ $V_R = 30\text{V}$	$I_F = 1\text{A}$	$di_F/dt = -15\text{A}/\mu\text{s}$			0.075	μC
I_{RM}	$T_j = 25^\circ\text{C}$ $V_R = 30\text{V}$	$I_F = 1\text{A}$	$di_F/dt = -15\text{A}/\mu\text{s}$			1.5	A

To evaluate the conduction losses use the following equations :

$$V_F = 1.15 + 0.008 I_F \quad P = 1.15 \times I_{F(AV)} + 0.008 I_F^2(\text{RMS})$$