

**MECHANICAL CASE OUTLINE**  
**PACKAGE DIMENSIONS**

**D2PAK / SMP-FD**  
**CASE 418AM**  
**ISSUE 0**

DATE 29 FEB 2012

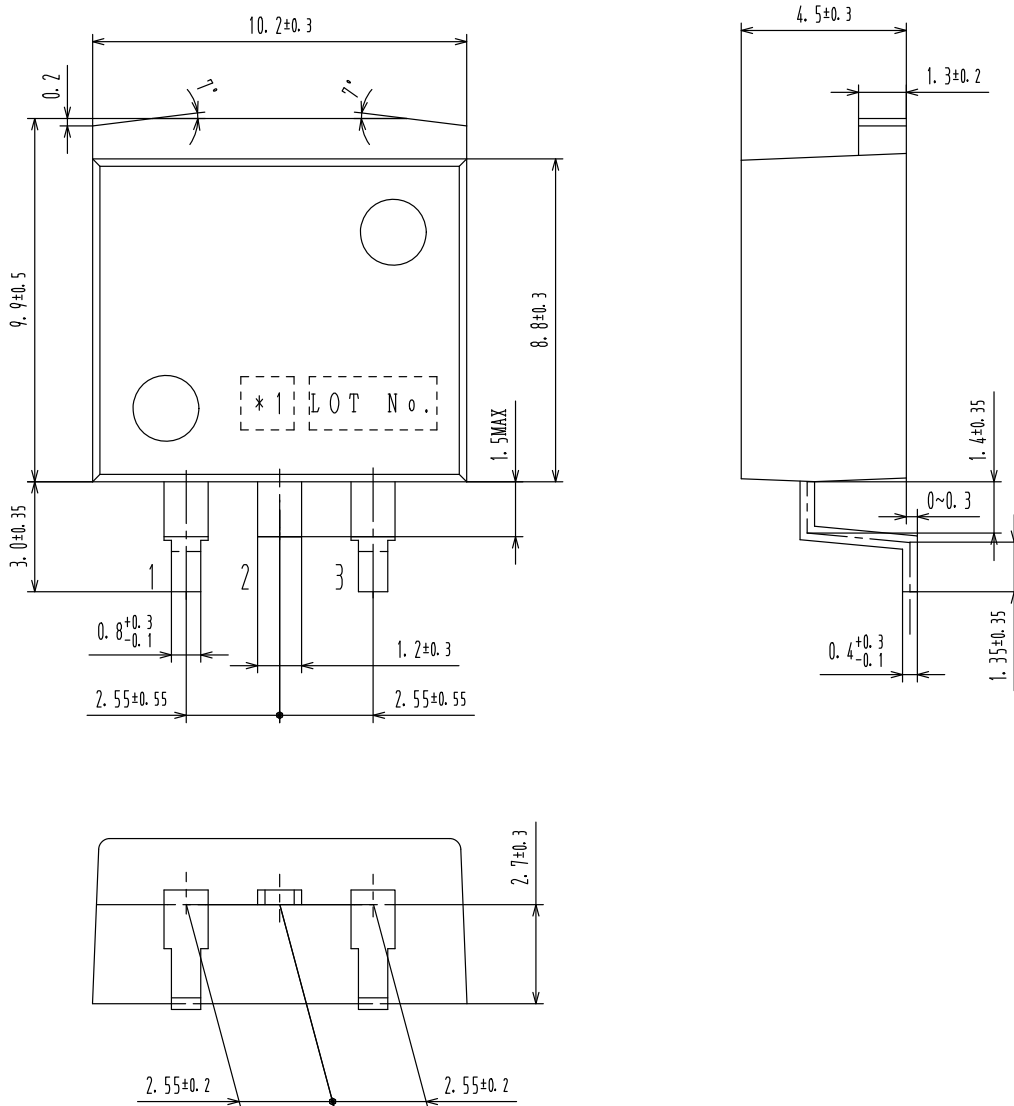

<b>DOCUMENT NUMBER:</b>	<b>98AON67427E</b>	Electronic versions are uncontrolled except when accessed directly from the Document Repository. Printed versions are uncontrolled except when stamped "CONTROLLED COPY" in red.
<b>STATUS:</b>	<b>ON SEMICONDUCTOR STANDARD</b>	
<b>NEW STANDARD:</b>		
<b>DESCRIPTION:</b>	<b>D2PAK / SMP-FD</b>	<b>PAGE 1 OF 2</b>

